

DEPARTMENT OF THE ARMY TECHNICAL MANUAL

OPERATOR AND ORGANIZATIONAL MAINTENANCE MANUAL,
POWER SUPPLY PP-1104C/G

Headquarters, Department of the Army, Washington, D. C. 20315

6 November 1964

WARNING

DANGEROUS VOLTAGES EXIST IN THIS EQUIPMENT

High voltages and currents exist in this equipment. Serious injury or death may result from contact with the input or output connections. Re-energize the equipment before connecting or disconnecting the load to be powered and before performing any maintenance.

DON'T TAKE CHANCES!

	Paragraph	Page
CHAPTER 1.	INTRODUCTION	
Section I.	General	
	Scope	1 5
	Index of equipment publication	2 5
	Forms and records	3 5
II.	Description and data	
	Purpose and use	4 5
	Technical characteristics	5 5
	Description of Power Supply PP-1104C/G	6 6
CHAPTER 2.	INSTALLATION AND OPERATING INSTRUCTIONS	
Section I.	Service upon receipt of equipment	
	Unpacking	7 7
	Checking unpacked equipment	8 7
	Placement of equipment	9 7
II.	Installation procedure	
	Connections	10 7
	Initial adjustment of equipment	11 9
III.	Operation	
	Operator's controls and indicators	12 9
	Preparation for operation	13 9
	Operating procedure	14 11
	Stopping procedure	15 11
CHAPTER 3.	MAINTENANCE INSTRUCTIONS	
	Scope of maintenance	16 12
	Preventive maintenance	17 12
	Preventive maintenance checks and services periods	18 12
	Daily preventive maintenance checks and services chart	19 12
	Weekly preventive maintenance checks and services chart	20 13
	Money preventive maintenance checks services chart	21 13

This reprint includes all changes in effect at the time of publication; changes 1 through 6.

	Paragraph	Page
	Quarterly preventive maintenance checks and services chart.....	22 14
	Cleaning	23 14
	Touchup painting instruction.....	24 14
	General troubleshooting information	25 14
	Troubleshooting chart.....	26 15
	Replaement of indicator lamp	27 15
CHAPTER 4.	SHIPMENT, LIMITED STORAGE, AND DEMOLITION TO	
	PREVENT ENEMY USE	
Section I.	Shipment and limited storage	
	Repackaging for shipment or limited storage	28 16
	Packing	29 16
II.	Demolition of materiel to prevent enemy use	
	Authority for demolition	30 17
	Methods of destruction.....	31 17
APPENDIX I.	REFERENCES	18
II.	MAINTENANCE ALLOCATION.....	19
III.	BASIC ISSUE ITEMS LIST	23

CHANGE }
No. 1 }

HEADQUARTERS
DEPARTMENT OF THE ARMY
WASHINGTON, D. C., 28 February 1968

**Operator and Organizational Maintenance Manual
POWER SUPPLY PP-1104C/G (WITH INSTRUCTIONS
FOR USE AS BATTERY CHARGER)**

TM 11-6130-246-12, 6 November 1964, is changed as follows:

The title of the manual is changed as shown above.

Page 5. Chapter 1 is superseded as follows:

**CHAPTER 1
INTRODUCTION**

Section I. GENERAL

1. Scope

This manual describes Power Supply PP-1104-C/G (fig. 1) and provides instruction for installation, power supply operation, battery charger operation, and operator and organizational maintenance. It includes instructions for cleaning and inspection of the equipment and replacement of parts available to the operator and organizational repairman. Power Supply PP-1104C/G is referred to as the *power supply* in this manual.

2. Indexes of Equipment Publications

a. DA Pam 310-4. Refer to DA Pam 310-4 to determine whether there are new editions, changes, or additional publications pertaining to the equipment.

b. DA Pam 310-7. Refer to DA Pam 310-7 to determine whether there are Modification Work Orders (MWO's) pertaining to the equipment.

3. Forms and Records

a. *Reports of Maintenance and Unsatisfactory Equipment.* Use equipment forms and records in accordance with instructions given in TM 38-750.

b. *Report of Packaging and Handling Deficiencies.* Fill out and forward DD Form 6 (Report of Packaging and Handling Deficiencies) as prescribed in AR 700-58 (Army), NAVSUP Publication 378 (Navy), AFR 71-4 (Air Force), and MCO P4610-5 (Marine Corps).

c. *Discrepancy in Shipment Report (DISREP)* (SF361). Fill out and forward Discrepancy in Shipment Report (DISREP) (SF361) as prescribed in AR 55-38 (Army), NAVSUP Pub 459 (Navy), AFM 75-34 (Air Force), and MCO P4610-19 (Marine Corps).

d. *Report of Equipment Publication Improvements.* Report of errors, omissions, and recommendations for improving this publication by the individual user is encouraged. Reports should be submitted on DA Form 2028 (Recommended Changes to DA Publications) and forwarded direct to Commanding General, U. S. Army Electronics Command, ATTN: AMSEL-ME-NMP-AD, Fort Monmouth, N.J. 07703.

4. Purpose and Use

Power Supply PP-1104C/G (fig. 1) converts 115 or 230 volts alternating current (ac) to 14 or 28 volts direct current (dc). This power supply is used in maintenance shops as a general purpose low-voltage dc power source.

5. Technical Characteristics

Power input:

- Voltage. 115 volts or 230 volts, 60 cps.
- Phase, Single.
- Current (full load) 24 amperes for 115-volt ac
input power or 12 amperes
for 230-volt ac input power

CHAPTER 2.1

USING POWER SUPPLY PP-1104C/G AS A BATTERY CHARGER

15.1. Purpose of Reverse Current Cutoff

A reverse current cutoff device is required to permit use of Power Supply PP-1104C/G as a battery charger. A battery connected to the output terminals of an inactivated PP-1104C/G can result in the battery discharging its stored power through the PP-1104C/G. Use Relay, Reverse Current Cutoff (FSN 5945-824-5585) connected between the output of the PP-1104C/G and the battery to be charged to prevent the battery from discharging through the PP-1104C/G. The special equipment required is given in paragraph 15.2. The connection instructions are given in paragraph 15.3.

15.2. Special Equipment Required

The special equipment required for use of the PP-1104C/G as a battery charger is given in a through e below.

a. Relay, Reverse Current Cutoff (FSN 5945-824-5585).

b. Wire, single conductor #16 AWG (FSN 6145-174-1107), length as required.

c. Wire, electrical, stranded #2 AWG (FSN 6145-854-7872), length as required for 100 amperes maximum at 14-volt operation.

d. Wire, electrical, stranded #4 AWG (FSN 6145-337-3188) length as required for 50 amperes maximum at 28-volt operation.

e. Mounting plywood board approximately three eighths inch thick, 10 inches long, and 10 inches wide.

15.3. Connections for Battery Charger Operation

(fig. 4.1)

a. Make sure that the circuit breaker switch on the PP-1104C/G is set to OFF. Connect #16 AWG wire from the GEN terminal to the SW terminal on the reverse current cutoff relay.

b. Connect #2 or #4 AWG wire from the positive terminal on the PP-1104C/G to the

GEN terminal on the reverse current cutoff relay.

c. Connect #2 or #4 AWG wire from the BAT terminal on the reverse current cutoff relay to the positive terminal of the battery to be charged.

d. Connect #16 AWG wire from the negative terminal of the PP-1104C/G to the NEG terminal on the reverse current cutoff relay.

e. Connect #2 or #4 AWG wire from the negative terminal of the PP-1104C/G to the negative terminal of the battery to be charged.

15.4 Charging Procedure

a. Perform the procedures given in paragraphs 10 and 11.

b. Connect the links for the desired output as shown on the front panel placard (fig. 4).

c. Perform the connection procedures given in paragraph 15.3.

Caution: A continuous flow of air through Power Supply PP-1104C/G is necessary during operation to prevent damage from overheating. Do not obstruct the louvers on each side of Power Supply PP-1104C/G or at the rear panel. If the fan fails to operate, discontinue operation.

d. Set the circuit breaker switch to ON. (Indicator lamp should glow.)

e. Check the VOLTS D.C. meter indication, and rotate the increase voltage switch clockwise until the desired output voltage is obtained. Check the output voltage at intervals during operation. When necessary, adjust the increase voltage switch to maintain the desired output voltage.

15.5 Stopping Procedure

Stop the battery charging operation as follows:

a. Set the circuit breaker switch to OFF. (Indicator lamp should extinguish.)

b. Set the increase voltage switch to 1.

c. Disconnect the battery from the equipment.

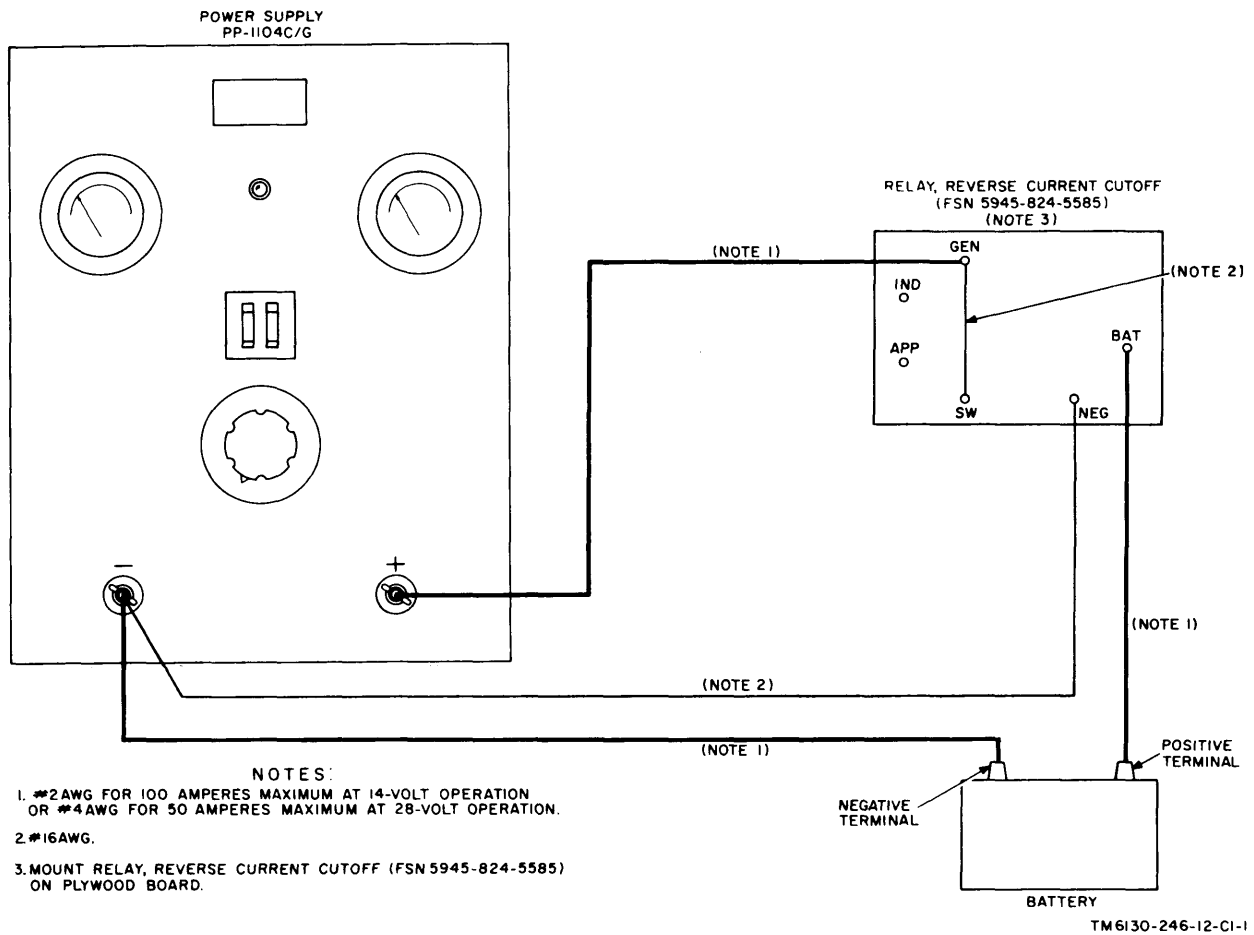

Figure 4.1. Battery charging connection diagram.

APPENDIX II

MAINTENANCE ALLOCATION

Section I. INTRODUCTION

1. General

This appendix provides a summary of the maintenance operations covered in the equipment literature for Power Supply PP-1104C/G. It authorizes categories of maintenance for specific maintenance functions on repairable items and components and the tools and equipment required to perform each function. This appendix may be used as an aid in planning maintenance operations.

2. Explanation of Format for Maintenance Allocation Chart.

a. Group Number. Not used.

b. Component Assembly Nomenclature. This column lists the item names of component units, assemblies, subassemblies, and modules on which maintenance is authorized.

c. Maintenance Function. This column indicates the maintenance category at which performance of the specific maintenance function is authorized. Authorization to perform a function at any category also includes authorization to perform that function at higher categories. The codes used represent the various maintenance categories as follows:

<i>Code</i>	<i>Maintenance Category</i>
C	Operator/Crew
O	Organizational Maintenance
F	Direct Support Maintenance
H	General Support Maintenance
D	Depot Maintenance

d. Tools and Equipment. The numbers appearing in this column refer to specific tools and equipment which are identified by these numbers in section III.

e. Remarks. Self explanatory.

3. Explanation of Format for Tool and Test Equipment Requirements

The columns in the tool and test equipment requirements chart are as follows:

a. Tools and Equipment. The numbers in this column coincide with the numbers used in the tools and equipment column of the MAC. The numbers indicate the applicable tool for the maintenance function.

b. Maintenance Category. The codes in this column indicate the maintenance category normally allocated the facility.

c. Nomenclature. This column lists tools, test, and maintenance equipment required to perform the maintenance functions.

d. Federal Stock Number. This column lists the Federal stock number.

e. Tool Number. Not used.

SECTION III. TOOL AND TEST EQUIPMENT REQUIREMENTS

TOOL AND TEST EQUIPMENT REQUIREMENTS				
TOOLS AND EQUIPMENT	MAINTENANCE CATEGORY	NOMENCLATURE	FEDERAL STOCK NUMBER	TOOL NUMBER
1	H,D	PP-1104C/G (continued) AMMETER ME-65/U	6625-752-8817	
2	O	MULTIMETER, AN/URM-105	6625-581-2036	
3	F,H,D	MULTIMETER, TS-352B/U	6625-553-0142	
4	H,D	OHMMETER, ZM-21A/U	6625-581-2466	
5	H,D	TEST SET, TV-100/U	6625-092-9136	
6	H,D	TEST SET, CAPACITOR ZM-3/U	6625-229-1060	
7	O	TOOL KIT, ELECTRONIC EQUIPMENT, TK-101/G	5180-064-5178	
8	H,D	TOOL KIT, ELECTRONIC EQUIPMENT, TK-105/G	5180-610-8177	
9	H,D	TRANSFORMER, VARIABLE POWER, TF-171A/U	5950-503-0632	
10	H,D	VOLTMETER, METER, ME-30()/U	6625-669-0742	

APPENDIX III BASIC ISSUE ITEMS

Section I. INTRODUCTION

1. Scope

This appendix lists items comprising an operable equipment and those required for installation, operation, or operator's maintenance for Power Supply PP-1104C/G.

2. Explanation of Columns

The following is a list of explanations of columns in section II.

a. Source, Maintenance, and Recoverability Codes (SMR) Column.

(1) *Source Code (S).* The selection status and source for the listed item is the first code indicated in this column. The source code and its explanation is:

<i>Code</i>	<i>Explanation</i>
P	Applies to repair parts that are stocked in or supplied from GSA/DSA, or Army Supply system, and authorized for use at indicated maintenance categories.

(2) *Maintenance code (M).* The lowest category of maintenance authorized to install the item is indicated by the second code in the column. The maintenance category code and its explanation is:

<i>Code</i>	<i>Explanation</i>
0	Organizational Maintenance

(3) *Recoverability code (R).* Not used.

Note. When no code is indicated in the recoverability column, the part will be considered expendable.

b. Federal Stock Number Column. This column indicates the Federal stock number for the item.

c. Description Column. This column includes the Federal item name and any additional description of the item which may be required. A part number or other reference number is followed by the applicable five-digit Federal Supply Code for Manufacturers. Usable on code column is not used.

d. Unit of Issue Column. The unit used as a basis of issue (e.g., ea, pr, ft, yd, etc.) is given in this column.

e. Quantity Incorporated in Unit Pack Column. Not used.

f. Quantity Incorporated in Unit Column. The total quantity of the item used in the equipment is given in this column.

g. Quantity Furnished With Equipment Column. This column indicates the quantity of an item furnished with the equipment in excess of the quantity incorporated in the unit.

h. Quantity Authorized Column. Not used.

i. Illustrations Column. Not used.

3. Federal Supply Codes

This paragraph lists the Federal supply code with the associated manufacturer's name.

<i>Code</i>	<i>Manufacturer</i>
00197	General Electric Distribution Corp.

SECTION II BASIC ISSUE ITEMS

(1) SMR CODE	(2) FEDERAL STOCK NUMBER	(3) DESCRIPTION Reference Number & Mfr Code	(4) UNIT OF ISSUE	(5) QTY INC IN UNIT PACK	(6) QTY INC IN UNIT	(7) QTY FURN WITH EQUIP	(8) QTY AUTH	(9) ILLUSTRATIONS	
								(a) FIG. NO.	(b) ITEM NO. OR REFERENCE DESIGNATION
P-0	6130-542-6385	POWER SUPPLY PP-11000/3: (This item is non-repairable) TECHNICAL MANUAL TM 11-6130-1046-10 NOTE: A quantity of one technical manual is packed with each equipment. Where a valid need exists, additional copies may be requisitioned and kept on hand.	ea		1				
	6240-223-9100	LAMP GLOW: NE-51; COLBY NO ACCESSORIES, TOOLS OR TEST EQUIPMENT ARE TO BE ISSUED WITH THIS EQUIPMENT NO BASIC ISSUE ITEMS ARE MOUNTED IN OR ON THIS EQUIPMENT	ea		1	1			

By Order of the Secretary of the Army:

HAROLD K. JOHNSON,
General, United States Army,
Chief of Staff.

Official:

KENNETH G. WICKHAM,
Major General, United States Army,
The Adjutant General.

Distribution:

Active Army:

USASA (2)
CNGB (1)
OACSC-E (7)
Dir of Trans (1)
CofEngrs (1)
TSG (1)
CofsptS (1)
USAARENBD (2)
USACDCEA (1)
USACDCCBRA (1)
USACDCCEA (1)
USACDCCEA, Ft. Huachuca (1)
USACDCTA (1)
USACDCADA (1)
USACDCARMA (1)
USACDCAVNA (1)
USACDCARTYA (1)
USACDCSWA (1)
USAMC (5)
USCONARC (5)
ARADCOM (5)
ARADCOM Rgn (2)
OS Maj Cored (4)
LOGCOMD (2)
USAMICOM (4)
USASTRATCOM (4)
USAESC (70)
MDW (1)
Armies (2) except
Eighth USA (5)
Corps (2)
USAC (3)
Svc Colleges (2)
USAADS (8)
USAAMS (2)
USAARMS (8)
USAIS (2)
USAES (2)
USASESS (8)
USAOC&S (8)
USATC Armor (2)
USATC Inf (2)
USASTC (2)
WRAMC (1)
Army Pic Cen (2)
USACDCEC (10)
Instl (2) except
Fort Hancock (4)
Fort Gordon (10)

Fort Huachuca (10)
WSMR (5)
Fort Carson (25)
Fort Knox (12)
Army Dep (2) except
LBAD (14)
SAAD (30)
TOAD (14)
LEAD (7)
SHAD (3)
NAAD (5)
SVAD (5)
CHAD (3)
ATAD (10)
Gen Dep (2)
Sig Sec Gen Dep (5)
Sig Dep (12)
Sig FLDMS (2)
AMS (1)
USAERDAA (2)
USAERDAW (13)
USACRREL (2)
MAAG (2)
USARMIS (2)
USARMA (2)
AAF (USARPAC) (5)
Units org under fol TOE
(2 copies each):
1-127
1-137
6-615
6-616
7
11-5
11-6
11-35
11-38
11-56
11-57
11-85
11-86
11-87
11-97
11-98
11-117
11-127
11-155
11-157
11-158

11-500 (AA-AC)	29-55
(KC, KD, RD, RP)	29-57
11-587	29-134
11-592	29-138
11-597	29-205
17	29-207
29-1	32-56
29-11	32-57
29-15	32-67
29-16	32-68
29-17	32-77
29-21	37
29-25	55-89
29-35	55-99
29-36	55-457
29-37	55-458
29-51	57

NG: State AG (3); units-same as active Army except allowance is one copy per unit.

USAR: None.

For explanation of abbreviations used, see AR 320-50.

CHANGE }
No. 2 }

HEADQUARTERS
DEPARTMENT OF THE ARMY
WASHINGTON, D, C., 20 January 1971

Operator's and Organizational Maintenance Manual
POWER SUPPLY PP-1104C/G (WITH INSTRUCTIONS FOR USE
AS BATTERY CHARGER)

TM 11-6130-246-12, 6 November 1964, is changed as follows:

NOTE

The parenthetical reference to a previous change (example page 5 of C 1) indicates that pertinent material was published in that change.

Change "FSN 5945-824-5585" to "FSN 5945-824-5575" in the following places:

Page 11. paragraph 15.1, line 7 (page 2 of C1).

Paragraph 15.2a, line 2 (page 2 of C 1).

Figure 4.1 (page 3 of C 1), in the upper right-hand section of the illustration under RELAY, REVERSE CURRENT CUTOFF.

Figure 4.1 (page 3 of C 1), note 3, line 1.

By Order of the Secretary of the Army:

W. C. WESTMORELAND,
General, United States Army,
Chief of Staff

Official:

KENNETH G. WICKHAM,
Major General, United States Army,
The Adjutant General.

Distribution:

Active Army:

USABA (2)
 CNGB (1)
 ACSC-E (2)
 Dir of Trans (1)
 CofEngrs (1)
 TSG (1)
 CofSptS (1)
 USAARENBD (2)
 USAMB (10)
 USACDC (2)
 USACDC Agcy (1)
 USAMC (1)
 CONARC (5)
 ARADCOM (2)
 ARADCOM Rgn (2)
 OS Maj Comd (4)
 LOGCOMD (5)
 USAMIOOM (4)
 USATECOM (2)
 USASTRATCOM (4)
 USAESC (70)
 MDW (1)
 Armies (2) except
 Eighth (10)
 Corps (2)
 1st Cav Div (3)
 Svc Colleges (2)
 USASENS (10)
 USAADS (5)
 USAFAS (2)
 USAARMS (5)
 USAIS (2)
 USAES (2)
 USAINTS (3)
 WRAMC (1)
 USACDCEA (10)
 USAOC&S (5)
 Inatl (2) except
 Fort Gordon (10)
 Fort Huachuca (10)
 Fort Carson (25)
 WSMR (3)
 ATS (1)
 USAERDAA (2)

Army Dep (2) except

LBAD (14)
 SAAD (30)
 TOAD (14)
 LEAD (7)
 NAAD (5)
 SVAD (5)
 ATAD (10)
 Gen Dep (2)
 Sig Sec Gen Dep (5)
 Sig Dep (10)
 Sig FLDMS (2)
 USAERDAW (5)
 USACRREL (2)
 MAAG (1)
 USARMIS (1)
 AAF (2)

Units org under fol TOE

(2 copies each):

1-127	29-27
1-137	29-35
6-615	29-36
6-616	29-37
7	29-51
11-15	29-55
11-16	29-57
11-56	29-134
11-85	29-136
11-87	2-138
11-97	29-206
11-98	29-207
11-117	32-56
11-158	32-57
11-500 (AA-AC, KC, KD, RD, RP)	32-67
17	37
29-1	55 89)
29-11	55 99
29-15	55 457
29-16	55 458
20-17	57
20-21	
29-25	
29-26	

NG: State AG (3): units -- same as active Army except allowance is one (1) copy to each unit

USAR: None.

For explanation of abbreviations used, see AR 310-50.

CHANGE }
No. 3 }

HEADQUARTERS
DEPARTMENT OF THE ARMY
WASHINGTON, D.C., 12 December 1973

**Operator's and Organizational Maintenance Manual
POWER SUPPLY PP-1104C/G
(WITH INSTRUCTIONS FOR USE AS A BATTERY CHARGER)**

TM 11-6130-246-12, 6 November 1964, is changed as follows:

Page 5. Paragraph 3 is superseded as follows:

3. Forms and Records

a. Reports of Maintenance and Unsatisfactory Equipment. Maintenance forms, records, and reports which are to be used by maintenance personnel at all maintenance levels are listed in and prescribed by TM 38-750.

b. Report of Packaging and Handling Deficiencies. Fill out and forward DD Form 6 (Report of Packaging and Handling Deficiencies) as prescribed in AR 700-58 (Army)/NAVSUP PUB 378 (Navy)/AFR 71-4 (Air Force)/ and MCO P4030.29 (Marine Corps).

c. Discrepancy in Shipment Report (DISREF) (SF 361). Fill out and forward Discrepancy in Shipment Report (DISREP) (SF 361) as prescribed in AR 55-38 (Army)/NAVSUP PUB 459 (Navy)/AFM 75-34 (Air Force)/and MCO P4610.19 (Marine Corps).

Paragraph 3.1 is added as follows:

3.1. Reporting of Equipment Publication Improvements

The reporting of errors, omissions, and recommendations for improving this publication by the individual user is encouraged. Reports should be submitted on DA Form 2028 (Recommended Changes to Publications) and forwarded direct to Commander, US Army Electronics Command, ATTN: AMSEL-MA-C, Fort Monmouth, NY 07703.

Page 6. Paragraph 6.1 is added as follows.

6.1. Item Comprising an Operable Power Supply PP-1104C/G

Power Supply PP-1104C/G (FSN 6130-542-6385) comprises an operable equipment and is shown in figure 1.

Page 7. The paragraph 8, subparagraph *a*, delete "(para 3)" from the second sentence.

In subparagraph *b*, delete the second sentence.

Page 23. Appendix III is deleted in its entirety.

By Order of the secretary of the Army:

CREIGHTON W. ABRAMS
General, United States Army
Chief of Staff

Official:

VERNE L. BOWERS
Major General *United States Army*
The Adjutant General

Distribution:

Active Army:

USASA (2)	LBAD (14)
CNGB (1)	SAAD (30)
ACSC-E (2)	TOAD (14)
Dir of Trans (1)	ATAD (10)
COE (1)	GENDEP (2)
TSG (1)	Sig Sec GENDEP (2)
USAARENBD (1)	Sig Dep (2)
USAMB (10)	SigFLDMS (1)
AMC (1)	USAERDAA (1)
TRADOC (2)	USAERDAW (1)
ARADCOM (2)	MAAG (1)
ARADCOM Rgn (2)	USARMIS (1)
OS Maj Comd (4)	AAF (1)
LOGCOMDS (3)	USAOC&S (2)
MICOM (2)	Units org under fol TOE
TECOM (2)	(1 cy each):
USACC (4)	1-127 20-25
MDW (1)	1-137 20-26
Armies (2)	6-615 29-27
Corps (2)	6-616 29-36
HISA (ECOM) (18)	7 29-36
Svc Colleges (1)	11-16 29-37
USASESS (6)	11-16 29-51
USAADS (2)	11-85 29-55
USAFAS (2)	11-86 29-57
USAARMS (2)	11-87 29-134
USAIS (2)	11-97 29-136
USAES (2)	11-98 29-207
USAINTS (3)	11-117 32-56
WRAMC (1)	11-168 32-57
USACDCEC (10)	11-500 (AA-AC) 32-67
ATS (1)	17 32-77
Instl (2) except:	29-1 37
Ft Gordon (10)	29-11 65-89
Ft Huachuca (10)	29-15 55-99
WSMR (1)	29-16 55-457
Ft Carson (5)	29-17 55-458
Ft Richardson (ECOM Ofc) (2)	29-21 57
Army Dep (2) except:	

NG: State AG (3); Units—Same as Active Army

USAR: None

For explanation of abbreviations used, see AR 310-50.

CHANGE }
No. 4 }

HEADQUARTERS
DEPARTMENT OF THE ARMY
WASHINGTON, DC, 10 January 1978

**Operator's and Organizational Maintenance Manual
POWER SUPPLY PP-1104C/G
(NSN 6130-00-542-6385)
(WITH INSTRUCTIONS FOR USE AS BATTERY CHARGER)**

TM 11-6130-246-12, 6 November 1964, is changed as follows:

The title of the manual is changed as indicated above.

Page 4. Add figure 1.1 after figure 1:

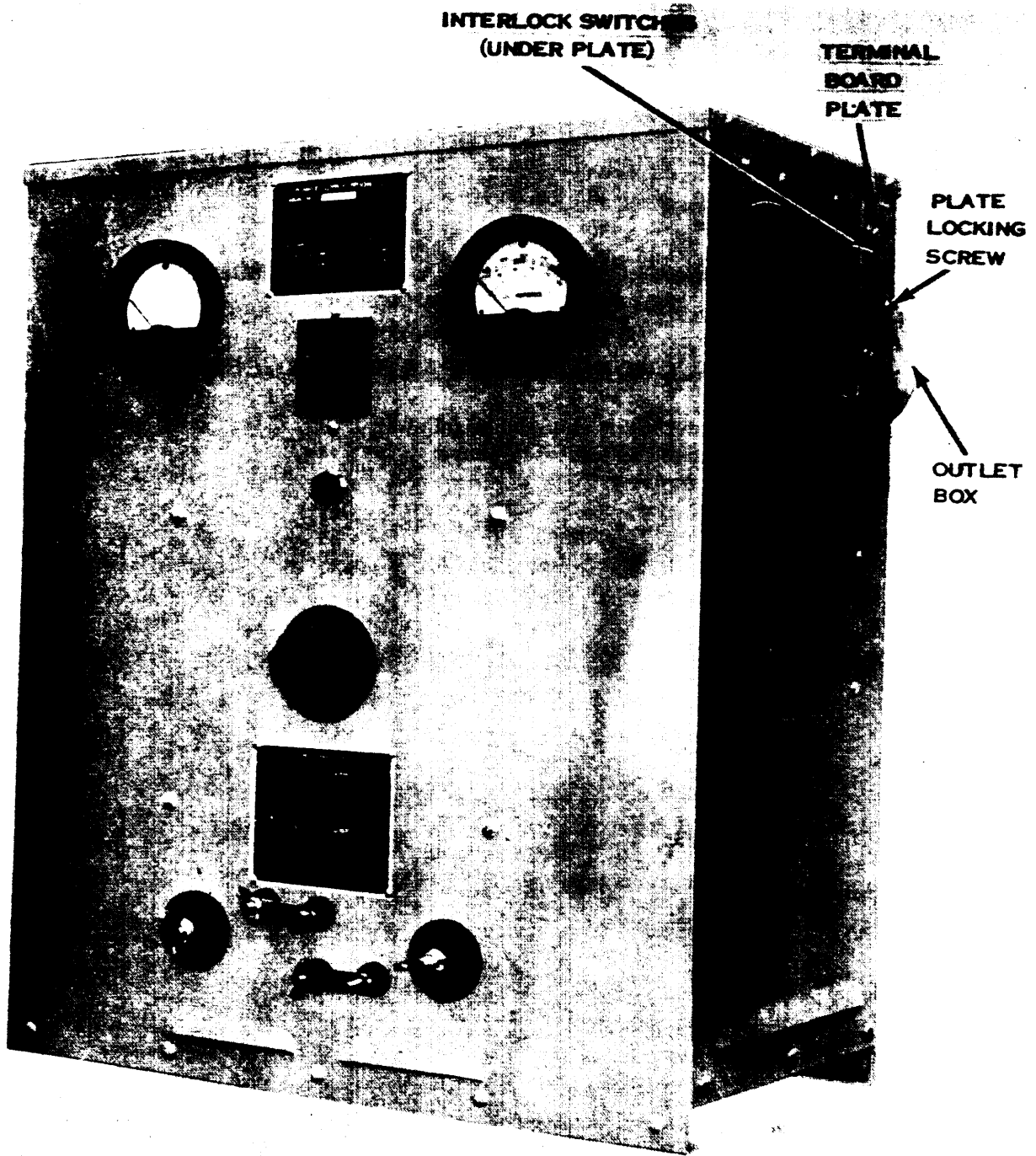

EL2TB001

Figure 1-1. Power Supply PP-1104C/G (procured under Contract No. DAAB07-76-C-1363).

Page 5, paragraph 3, Paragraph 3 is superseded as follows:

3. Forms and Records

a. Reports of Maintenance and Unsatisfactory Equipment. Maintenance forms, records, and reports which are to be used by maintenance personnel at all maintenance levels are listed in and prescribed by TM 38-750.

b. Reports of Packaging and Handling Deficiencies. Fill out and forward DD Form 6 (Packaging Improvement Report) as prescribed in AR 700-58/NAVSUPINST 4030.291AFR 71-13/MCO P4030.29A, and DSAR 4145.8.

c. Discrepancy in Shipment Report (DISREP) (SF 361). Fill out and forward Discrepancy in Shipment Report (DISREP) (SF 361) as prescribed in AR 55-38/NAVSUPINST 4610,33M AFR 76-18/MCO P4610.19B, and DSAR 4500-15.

Page 6, paragraph 6. After the last sentence, add:

On units procured on Contract No. DAAB07-76-C-1363, interlock switches are located under the terminal board plate (fig. 1.1). These interlock switches disconnect ac power from the terminal board (fig. 3) when the terminal board plate is opened.

Page 7, paragraph 10, heading. Under the heading, add:

Warning. Equipment must be grounded in accordance with ANSI-CI-1975 National Electric Code.

Page 9, paragraph 10. Subparagraphs *b* through *f* are superseded as follows:

b. On units other than those procured on Contract No. DAAB07-76-C-1363, remove the screws and lift off the top cover of the power supply.

WARNING!

Insure that the power input cable is disconnected from any source of ac power. If the ac power is connected directly to the power input cable, disconnect power by operating the main power switch in the building or shelter.

c. Remove the cover and appropriate knockout plug from the outlet box (figs. 1 and 1.1) on the rear of the power supply. Pass the power input cable through the knockout hole and attach to the outlet box with a cable clamp. Make sure the

cable clamp nut is tightened securely.

d. Attach the ground wire of the power input cable to the outlet box, using the screw provided.

e. On units procured on Contract No. DAAB07-76-C-1363, attach the white and black leads extending from the grommet in the outlet box to the two remaining wires of the power input cable. On all other units, connect one lead of the power input cable to terminal 1 of the terminal board (fig. 3) and the other lead to terminal 4.

f. If removed in *b* above, replace the top cover of the power supply and secure with the previously removed screws.

g. Open the hinged board plate (figs. 1 and 1.1) to check the terminal board connections (fig. 3). If the input power is 115-volts ac, terminal 1 must be strapped to terminal 3 and terminal 2 must be strapped to terminal 4 (A, fig. 3). If the input power is 230-volts ac, terminal 2 must be strapped to terminal 3 (B, fig. 3).

NOTE

Terminals 4 and 5 must always be strapped together to assure operation of the fan motor.

h. Close the terminal board plate (figs. 1 and 1.1) and tighten the plate locking screw until the plate is secured.

NOTE

On units procured on Contract No. DAAB07-76-C-1363, interlock switches are located under the terminal board plate. The power supply will not operate until the terminal board plate is secured tightly and the interlock switches engaged.

Page 11, Paragraph 14a is superseded as follows:

a. Assure the locking plate screw (figs. 1 and 1.1) is tightened securely. Units procured on Contract No. DAAB07-76-C1363 have interlock switches located under the terminal board plate and will not operate unless they are engaged (pushed in by the terminal board plate). Set the circuit breaker switch (fig. 4) to ON. The indicator lamp should glow.

Page 15, paragraph 26, troubleshooting chart. Item 8a is superseded as follows:

Trouble-symptom	Probable cause	Checks and corrective measures
a. Indicator lamp does not glow.	a. No power input, loose interlock switch, or defective indicator lamp.	a. Check input power. If correct, tighten screw on terminal board plate. Replace indicator lamp.

Page 14, paragraph 23. The Warning notice is superseded as follows:

WARNING!

The fumes of TRICHLOROETHANE are toxic. Provide thorough ventilation whenever it is used; avoid prolonged or repeated breathing of vapor. Do not use near an open flame or hot surface; trichloroethane is non-flammable but heat converts the fumes to a highly toxic phosgene gas the inhalation of

which could result in serious injury or death. Prolonged or repeated skin contact with trichloroethane can cause skin inflammation. When necessary, use gloves, sleeves, and aprons which solvent cannot penetrate.

Subparagraph *b*, third line. Delete “Cleaning Compound (FSN 7930-395-9542)” and substitute: Trichloroethane.

Page 19. Appendix II is superseded as follows:

APPENDIX II

MAINTENANCE ALLOCATION

Section I. INTRODUCTION

1. General

This appendix provides a summary of the maintenance operations for PP-1104C/G. It authorizes categories of maintenance for specific maintenance functions on repairable items and components and the tools and equipment required to perform each function. This appendix may be used as an aid in planning maintenance operations.

2. Maintenance Function.

Maintenance functions will be limited to and defined as follows:

a. Inspect. To determine the serviceability of an item by comparing its physical, mechanical, and/or electrical characteristics with established standards through examination.

b. Test. To verify serviceability and to detect incipient failure by measuring the mechanical or electrical characteristics of an item and comparing those characteristics with prescribed standards.

c. Service. Operations required periodically to keep an item in proper operating condition, i.e., to clean (decontaminate), to preserve, to drain, to paint, or to replenish fuel, lubricants, hydraulic fluids, or compressed air supplies.

d. Adjust. To maintain, within prescribed limits, by bringing into proper or exact position, or by setting the operating characteristics to the specified parameters.

e. Align. To adjust specified variable elements of an item to bring about optimum or desired performance.

f. Calibrate. To determine and cause corrections to be made or to be adjusted on instruments or test measuring and diagnostic equipments used in precision measurement. Consists of comparisons of two instruments, one of which is a certified standard of known accuracy, to detect and adjust any discrepancy in the accuracy of the instrument being compared.

g. Install. The act of emplacing, seating, or fixing into position an item, part, module (component or assembly) in a manner to allow the proper functioning of the equipment or system.

h. Replace. The act of substituting a serviceable like type part, subassembly, or module

(component or assembly) for an unserviceable counterpart.

i. Repair. The application of maintenance services (inspect, test, service, adjust, align, calibrate, replace) or other maintenance actions (welding, grinding, riveting, straightening, facing, remachining, or resurfacing) to restore serviceability to an item by correcting specific damage, fault, malfunction, or failure in a part, subassembly, module (component or assembly), end item, or system.

j. Overhaul. That maintenance effort (service/action) necessary to restore an item to a completely serviceable/operational condition as prescribed by maintenance standards (i.e., DMWR) in appropriate technical publications. Overhaul is normally the highest degree of maintenance performed by the Army. Overhaul does not normally return an item to like new condition.

k. Rebuild. Consists of those services/actions necessary for the restoration of unserviceable equipment to a like new condition in accordance with original manufacturing standards. Rebuild is the highest degree of materiel maintenance applied to Army equipment. The rebuild operation includes the act of returning to zero those age measurements (hours, miles, etc) considered in classifying Army equipments/components.

3. Column Entries

a. Column 1, Group Number. Column 1 lists group numbers, the purpose of which is to identify components, assemblies, subassemblies, and modules with the next higher assembly.

b. Column 2, Component/Assembly. Column 2 contains the noun names of components, assemblies, subassemblies, and modules for which maintenance is authorized.

c. Column 3, Maintenance Functions. Column 3 lists the functions to be performed on the item listed in column 2. When items are listed without maintenance functions, it is solely for purpose of having the group numbers in the MAC and RPSTL coincide.

d. Column 4, Maintenance Category. Column 4 specifies, by the listing of a "worktime" figure in

the appropriate subcolumn (s), the lowest level of maintenance authorized to perform the function listed in column 3. This figure represents the active time required to perform that maintenance function at the indicated category of maintenance. If the number or complexity of the tasks within the listed maintenance function vary at different maintenance categories, appropriate "worktime" figures will be shown for each category. The number of task-hours specified by the "worktime" figure represents the average time required to restore an item (assembly, subassembly, component, module, end item or system) to a serviceable condition under typical field operating conditions. This time includes preparation time, troubleshooting time, and quality assurance/quality control time in addition to the time required to perform the specific tasks identified for the maintenance functions authorized in the maintenance allocation chart. Subcolumns of column 4 are as follows:

- C — Operator/Crew
- O — Organizational
- F — Direct Support
- H — General Support
- D — Depot

e. Column 5, Tools and Equipment. Column 5 specifies by code, those common tool sets (not individual tools) and special tools, test, and support equipment required to perform the designated function.

f. Column 6, Remarks. Column 6 contains an

alphabetic code which leads to the remark in section IV, Remarks, which is pertinent to the item opposite the particular code.

4. Tool and Test Equipment Requirements (See III)

a. Tool or Test Equipment Reference Code. The numbers in this column coincide with the numbers used in the tools and equipment column of the MAC. The numbers indicate the applicable tool or test equipment for the maintenance functions.

b. Maintenance Category. The codes in this column indicate the maintenance category allocated the tool or test equipment.

c. Nomenclature. This column lists the noun names and nomenclature of the tools and test equipment required to perform the maintenance functions.

d. National/NATO Stock Number. This column lists the National/NATO stock number of the specific tool or test equipment.

e. Tool Number. This column lists the manufacturer's part number of the tool followed by the Federal Supply Code for manufacturers (5-digit) in parentheses.

5. Remarks (See IV)

a. Reference Code. This code refers to the appropriate item in section II, column 6.

b. Remarks. This column provides the required explanatory information necessary to clarify items appearing in section II.

SECTION II MAINTENANCE ALLOCATION CHART
FOR
POWER SUPPLY PP-1104C/G

(1) GROUP NUMBER	(2) COMPONENT/ASSEMBLY	(3) MAINTENANCE FUNCTION	(4) MAINTENANCE CATEGORY					(5) TOOLS AND EQPT.	(6) REMARKS	
			C	O	F	H	D			
00	POWER SUPPLY PP-1104C/G	Service	0.1						A	
		Adjust	0.1						B	
		Test	0.1						B	
		Replace	0.1						C	
		Inspect		0.1				1		
		Service		0.2				1		
		Adjust		0.1				1	D	
		Test		0.1				2	E	
		Replace		0.1				1	F	
		Test				2.0			4	G
		Repair				3.0			3	H
		Test					2.0		3thru10	I
		Repair					3.0		3	J
Overhaul						24.0	3thru10			

SECTION III. TOOL AND TEST EQUIPMENT REQUIREMENTS
FOR
POWER SUPPLY PP-1104C/G

TOOL OR TEST EQUIPMENT REF CODE	MAINTENANCE CATEGORY	NOMENCLATURE	NATIONAL/NATO STOCK NUMBER	TOOL NUMBER
1	O	TOOL KIT, ELECTRONIC EQUIPEMNT TK-101/G	5180-00-064-5178	
2	O	MULTIMETER AN/URM-105()	6625-00-581-2036	
3	F,H,D	TOOL KIT, ELECTRONIC EQUIPMENT TK-105/G	5180-00-610-8177	
4	F,H,D	MULTIMETER AN/USM-223 (R# TS-352B/U)	6625-00-999-7465	
5	H,D	MULTIMETER AN/USM-33	6625-00-648-9172	
6	H,D	OHMMETER ZM-21A/U	6625-00-581-2466	
7	H,D	TEST SET, CAPACITOR ZM-3()/U	6625-00-229-1060	
8	H,D	TRANSFORMER, VARIABLE POWER TP-171A/F	5950-00-503-0632	
9	H,D	VOLTMETER, ELECTRONIC AN/USM-265	6625-00-054-3487	
10	H,D	DUMMY LOAD, ELECTRICAL DA-638/U	6625-00-422-2111	

SECTION IV. REMARKS

REFERENCE CODE	REMARKS
A	EXTERIOR.
B	OPERATIONAL.
C	INDICATOR LAMP.
D	LINKAGE.
E	CONTINUITY, INPUT AND OUTPUT VOLTAGES.
F	KNOBS AND LENS.
G	COMPONENTS.
H	COMPONENTS, METERS, FAN AND MOTOR, SHUNT.
I	ALL TESTS.
J	ALL REPAIRS.

By Order of the Secretary of the Army:

BERNARD W. ROGERS
General, United States Army
Chief of Staff

Official:

J. C. PENNINGTON
Brigadier General, United States Army
The Adjutant General

Distribution:

Active Army:

HISA (33)	1-137
USAINSCOM (3)	6-615
COE (1)	6-616
TSG (1)	7
USAARENBD (1)	11-15
DARCOM (1)	11-16
TRADOC (2)	11-85
OS Maj Comd (4)	11-86
TECOM (2)	11-87
USACC (4)	11-97
MDW (1)	11-98
Armies (2)	11-117
Corps (2)	11-500(AA-AC)
Svc Colleges (1)	17
USASIGS (5)	29-1
USAADS (2)	29-11
USAFAS (2)	29-15
USAARMS (2)	29-16
USAIS (2)	29-17
USAES (2)	29-21
USAICS (3)	29-25
MAAG (1)	29-26
USARMIS (1)	29-27
USAERDAA (1)	29-35
USAERDAW (1)	29-36
USAOC&S (2)	29-37
Fort Gordon (10)	29-51
Fort Huachuca (10)	29-55
Fort Carson (5)	29-57
Ft Richardson (ECOM) (2)	29-134
Army Dep (1) except	29-136
LBAD (14)	29-207
SAAD (30)	32-56
TOAD (14)	32-57
SHAD (3)	37
Fort Gillem (10)	55-89
USA Dep (1)	55-99
Sig Sec USA Dep (1)	55-457
Units org under fol TOE: (1)	55-458
1-127	57

NG: State AG (3); Units — Same as Active Army

USAR: None

For explanation of abbreviations used see, AR 310-50

CHANGE }
No. 5 }

HEADQUARTERS
DEPARTMENT OF THE ARMY
WASHINGTON, DC, 13 November 1979

**Operator's and Organizational Maintenance Manual
POWER SUPPLY PP-1104C/G
(NSN 6130-00-542-6385)
(WITH INSTRUCTIONS FOR USE AS BATTERY CHARGER)**

TM 11-6130-246-12, 6 November 1964, is changed as follows:

Page 1. WARNING. Above "DON'T TAKE CHANCES," add:

Adequate ventilation should be provided while using TRICHLOROTRIFLUOROETHANE. Prolonged breathing of vapor should be avoided. The solvent should not be used near heat or open flame; the products of decomposition are toxic and irritating. Since TRICHLOROTRIFLUOROETHANE dissolves natural oils, prolonged contact with skin should be avoided. When necessary, use gloves which the solvent cannot penetrate. If the solvent is taken internally, consult a physician immediately.

THE PP-1104C/G IS EXTREMELY HEAVY!

The PP-1104C/G is extremely heavy and requires a two-man lift. Use extreme care in handling the unit to avoid serious personnel injury and protect the unit from damage. If the PP-1104C/G does not have handles, ensure a good grip before lifting.

Below "DON'T TAKE CHANCES", add:

REPORTING OF ERRORS

You can help improve this manual. If you find any mistakes or if you know of a way to improve the procedures, please let us know. Mail your letter or DA Form 2028 directly to Commander, US Army Communications and Electronics Materiel Readiness Command, ATTN: DRSEL-ME-MQ, Fort Monmouth, NJ 07703. A reply will be furnished to you.

Page 5. Add paragraph 3.1 after paragraph 3.

3.1. Reporting Equipment Improvement Recommendations (EIR's)

EIR's can and must be submitted by anyone who is aware of an unsatisfactory condition with the equipment design or use. It is not necessary to show a new design or list a better way to perform a procedure, just simply tell why the design is unfavorable or why a procedure is difficult. EIR's may be submitted on Standard Form (SF) 368, Quality Deficiency Report. Mail directly to Commander, US Army Communications and Electronics Materiel Readiness Command, ATTN:DRSEL-ME-MQ, Fort Monmouth, NJ 07703. A reply will be furnished directly to you.

Page 14, paragraph 23. The warning notice and subparagraph b are superseded as follows:

WARNING

Adequate ventilation should be provided while using TRICHLOROTRIFLUOROETHANE. Prolonged breathing of vapor should be avoided. The solvent should not be near heat or open flame; the products of decomposition are toxic and irritating. Since TRICHLOROTRIFLUOROETHANE dissolves natural oils, prolonged contact with skin should be avoided. When necessary, use gloves which the solvent cannot penetrate., If the solvent is taken internally, consult a physician immediately.

b. Remove grease, fungus, and ground-in dirt from the case; use a cloth dampened with

TM 11-6130-246-12

**Cleaning Compound, Freon type TF (NSN
6850-00-105-3084).**

By Order of the Secretary of the Army:

E. C. MEYER
General, United States Army
Chief of Staff

Official:

J. C. PENNINGTON
Major General, United States Army
The Adjutant General

Distribution:

Active Army:	Army Dep (1) except:	29-25 (1)
HISA (Ft Monmouth) (21)	LBAD (14)	29-26 (1)
USAINSCOM (2)	SAAD (30)	29-27 (1)
COE (1)	SHAD (3)	29-35 (1)
TSG (1)	TOAD (14)	29-36 (1)
USAARENBD (1)	USA Dep (1)	29-37 (1)
DARCOM (1)	Sig Sec USA Dep (1)	29-51 (1)
TRADOC (2)	Units org under fol TOE:	29-55 (1)
OS MAJ COMD (4)	29-207 (2)	29-134 (1)
TECOM (2)	29-610 (2)	29-136 (1)
USACC (4)	1-127 (1)	29-207 (1)
MDW (1)	1-137 (1)	32-56 (1)
Armies (2)	6-615 (1)	32-57 (1)
Corps (2)	6-616 (1)	37- (1)
Svc Colleges (1)	7- (1)	55-89 (1)
USASIGS (5)	11-15(1)	55-99 (1)
USAADS (2)	11-16 (1)	55-99 (1)
USAFAS (2)	11-85(1)	55-457 (1)
USAARMS (2)	11-86(1)	55-458 (1)
USAIS (2)	11-87 (1)	57-(1)
USAES (2)	11-97 (1)	
USAICS (3)	11-98(1)	
MAAG (1)	11-117(1)	
USARMIS (1)	11-500 (AA-AC) (1)	
USAERDAA (1)	17- (1)	
USAERDAW (1)	29-1 (1)	
USAOC&S (2)	29-11 (1)	
Ft Carson (5)	29-15 (1)	
Ft Gillem (10)	29-16 (1)	
Ft Gordon (10)	29-17 (1)	
Ft Richardson (CERCOM Ofc) (2)	29-21 (1)	

ARNG: State AG (3); Units — Same as Active Army.

USAR, None.

For explanation of abbreviations used, see AR 310-50.

Change }
No. 6 }

HEADQUARTERS
DEPARTMENT OF THE ARMY
Washington, DC, 29 April 1982

**Operator's and Organizational Maintenance Manual
POWER SUPPLY PP-1104C/G
(NSN 6130-00-542-6385)
(WITH INSTRUCTIONS FOR USE AS BATTERY CHARGER)**

TM 11-6130-246-12, 6 November 1964, is changed as follows:

Page 1. Second WARNING, THE PP-1104C/G IS EXTREMELY HEAVY! is superseded as follows:

WARNING

Power Supply PP-1104C/G weighs 152 pounds. Be careful when moving. Mechanical lift required.

Page 2. After table of contents add the following safety steps.



5

SAFETY STEPS TO FOLLOW IF SOMEONE IS THE VICTIM OF ELECTRICAL SHOCK

1

DO NOT TRY TO PULL OR GRAB THE INDIVIDUAL

2

IF POSSIBLE, TURN OFF THE ELECTRICAL POWER

3

IF YOU CANNOT TURN OFF THE ELECTRICAL POWER, PULL, PUSH, OR LIFT THE PERSON TO SAFETY USING A WOODEN POLE OR A ROPE OR SOME OTHER INSULATING MATERIAL

4

SEND FOR HELP AS SOON AS POSSIBLE

5

AFTER THE INJURED PERSON IS FREE OF CONTACT WITH THE SOURCE OF ELECTRICAL SHOCK, MOVE THE PERSON A SHORT DISTANCE AWAY AND IMMEDIATELY START ARTIFICIAL RESUSCITATION

Page 7. Paragraph 7b. The following is added after "Removing Contents."

WARNING

Power Supply PP-1104/G weighs 152 pounds. Be careful when moving. Mechanical lift required.

Page 11. Paragraph 15.1, line 7. Delete (FSN 5945-824-5585) and substitute (NSN 5945-00-824-5575).

Paragraph 15.2a. Delete (FSN 5945-824-5585) and substitute (NSN 5945-00-824-5575).

Figure 4-1 is superseded as follows:

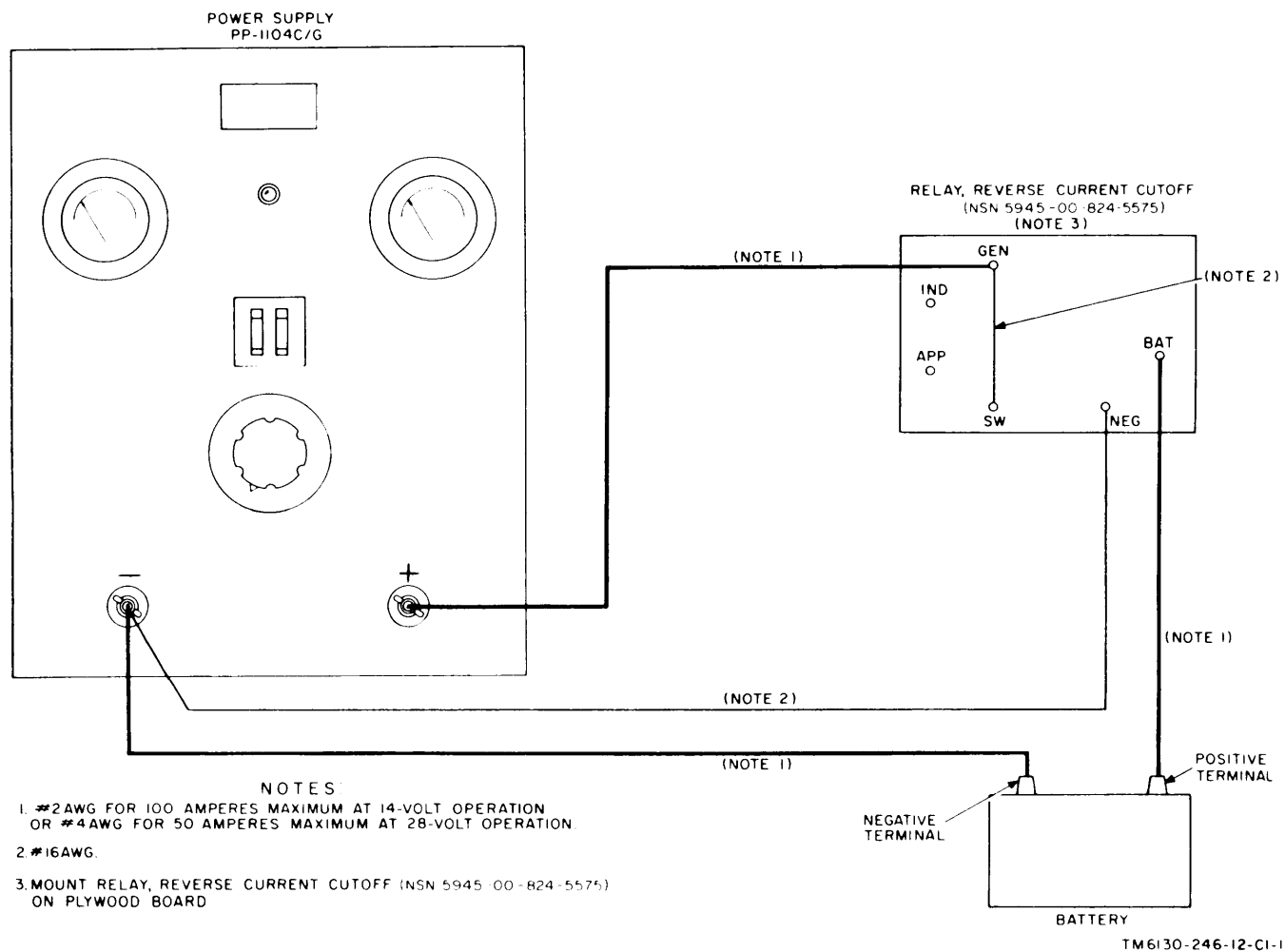

Figure 4-1. Battery charging connection diagram.

By Order of the Secretary of the Army:

E. C. MEYER
General, United States Army
Chief of Staff

Official:

ROBERT M. JOYCE
Brigadier General, United States Army
The Adjutant General

Distribution:

To be distributed in accordance with Special Mailing List.

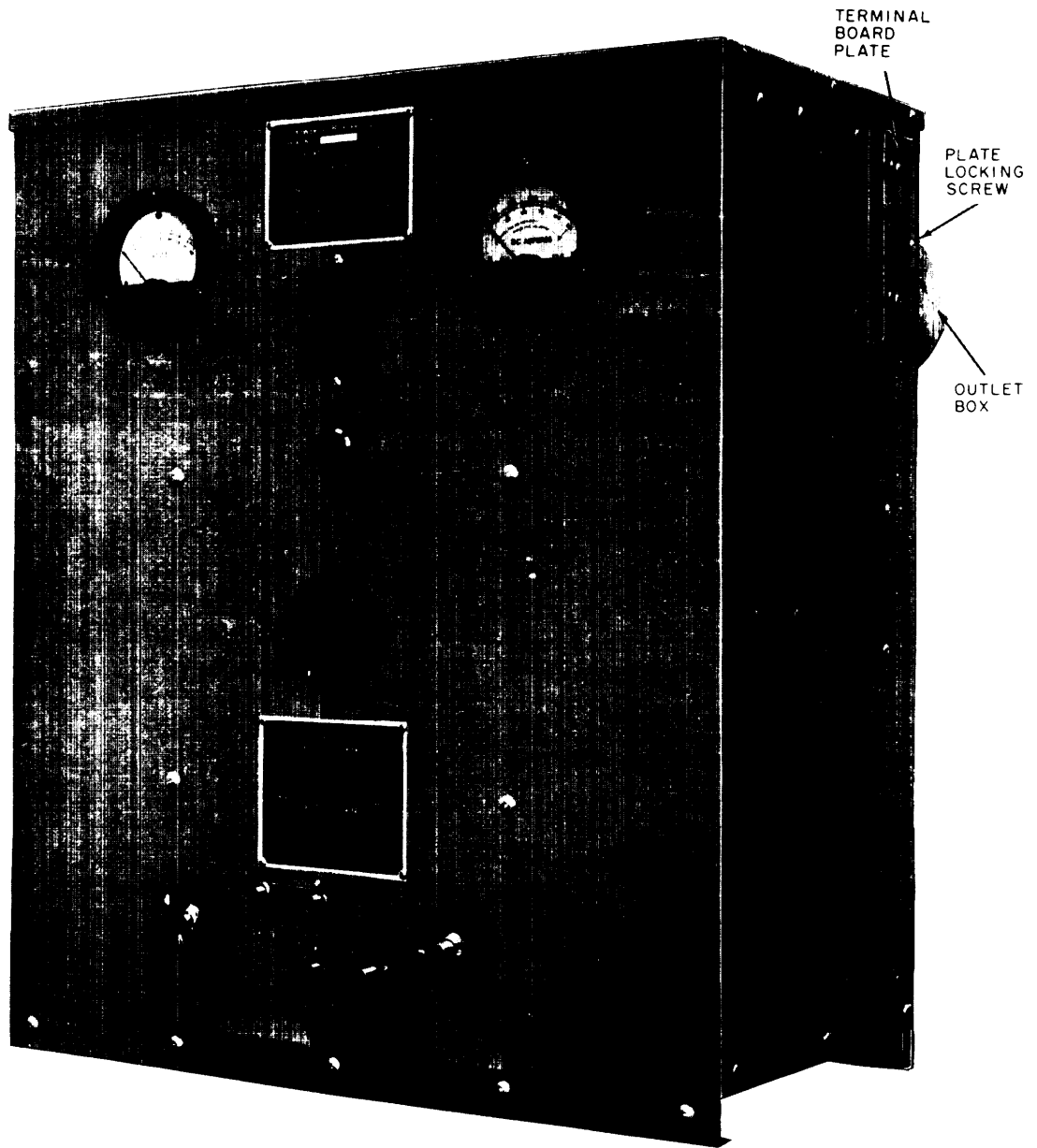

TM6130-246-12-1

Figure 1. Power Supply PP-1104C/G.

CHAPTER 1

INTRODUCTION

Section I. GENERAL

1. Scope

This manual describes Power Supply PP-1104C/G (fig. 1) and provides instruction for installation, operation, and operator and organizational maintenance. It includes instructions for cleaning and inspection of the equipment, and replacement of parts available to the operator and organizational repairman. Power Supply PP-1104C/G is referred to as *power supply* in this manual.

2. Index of Equipment Publications

Refer to the latest issue of DA Pam 310-4 to determine whether there are new editions, changes, or additional publications pertaining to the equipment. Department of the Army Pamphlet No. 310-4 is a current index of technical manuals, technical bulletins, supply manuals, supply catalogs, supply bulletins, lubrication orders, and modification work orders available through publications supply channels. The index lists the individual parts (-10, -20, -35P, etc) and the latest changes and revisions of each equipment publication.

3. Forms and Records

a. Reports of Maintenance and Unsatisfac-

tory Equipment. Use equipment forms and records in accordance with instructions in TM 38-750.

b. Reporting of Damaged or improper Shipment. Fill out and forward DD Form 6 (Report of Damaged or Improper Shipment) as prescribed in AR 700-58 (Army), NAVSANDA Publication 378 (Navy), and AFR 71-4 (Air Force).

c. Reporting of Equipment Manual improvements. The direct reporting, by the individual user, of errors, omissions, and recommendations for improving this equipment manual is authorized and encouraged. DA Form 2028 will be used for reporting these improvements. This form may be completed by the use of pencil, pen, or typewriter. DA Form 2028 will be completed in triplicate and forwarded by the individual using the manual. The original and one copy will be forwarded direct to: Commanding General, U. S. Army Electronics Command, ATTN: AMSEL-MR-MA, Fort Monmouth, New Jersey 07703. One information copy will be provided to the individual's immediate supervisor (officer, noncommissioned officer, supervisor, etc).

Section II. DESCRIPTION AND DATA

4. Purpose and Use

Power Supply PP-1104C/G (fig. 1) converts 115 or 230 volts alternating current (ac) to 14 or 28 volts direct current- (dc). This power supply is used in maintenance shops as a general purpose low-voltage dc power source.

5. Technical Characteristics

Power input:

Voltage	116 volts or 230 volts, 60 cps.
Phase	Single.
Current (full load)	24 amperes for 115-volt ac input power or 12 amperes for 230-volt ac input power.

Power output	
Voltage	Variable from 11.5 to 17.5 volts dc (14-volt operation) or variable from 23 to 35 volts dc (28-volt operation),
Maximum current	100 amperes at 14-volt operation or 50 amperes at 28-volt operation.
Ripple voltage	0.9 percent (root mean square).
Regulation	6 percent (14-volt operation) or 4 Percent (28-volt operation).

Operating temperature +32° F (0° C) to 115° F (51.7° C).

6. Description of Power Supply PP-1104C/G

The power supply is a self-contained unit in a metal cabinet, 23¼ inches high, 19 3/8 inches wide, and 13 1/8 inches deep. All operating controls are mounted on the front panel (fig. 1). Louvers on each side and the rear, and a grill at the bottom of the cabinet are provided for air circulation. A metal outlet box is mounted on the rear panel for connection of the input cable. The power supply weighs 152 pounds and includes one spare indicator lamp and two technical manuals. The spare indicator lamp is padded and taped to the lower rear skid channel on the right side of the power supply.

CHAPTER 2

INSTALLATION AND OPERATING INSTRUCTIONS

Section I SERVICE UPON RECEIPT OF EQUIPMENT

7. Unpacking

a. Packaging Data. When packed for shipment, Power Supply PP-1104C/G is placed in cartons and packed in a 30¾ by 25¼-by 18½-inch wooden packing case. A typical wooden packing case and its contents are shown in figure 2. The volume is 8.3 cubic feet and the total weight is 225 pounds.

b. Removing Contents.

- (1) Remove the nails from the top and one side of the wooden packing case with a nailpuller. Remove the top and side.
- (2) Tilt the wooden packing case toward the open side and slide the wooden packing crate free from the power supply.

Caution: Remove the power supply from the cartons carefully to prevent damage to the meters or operating controls on the front panel.

- (3) Open the outer carton, moisture-vaporproof barrier, and the inner carton and remove the power supply.

8. Checking Unpacked Equipment

a. Inspect the equipment for damage in-

curring during shipment. If the equipment has been damaged, report the damage on DD Form 6 (para 3).

b. See that the equipment is complete as listed on the packing slip. If a packing slip is not available, check the equipment against the basic issue items list (appx III). Report all discrepancies in accordance with TM 38-750. Shortage of a minor assembly or part that does not affect proper functioning of the equipment should not prevent use of the equipment.

c. If the equipment has been used or reconditioned, see whether it has been changed by a modification work order (MWO). If the equipment has been modified, the MWO number will appear on the front panel near the nomenclature plate. If modified, see that any operational instruction changes resulting from the modification have been entered in the equipment manual.

Note: Current MWO's applicable to the equipment are listed in DA Pam 310-4.

9. Placement of Equipment

Select a location that is convenient to the power input source and for connection of the load to the power supply. Provide at least 8 inches of space behind and on each side of the power supply for air circulation.

Section II. INSTALLATION PROCEDURE

10. Connections

Note. The power input line electrical connections are made by authorized installation personnel and should be protected with a 30-ampere fuse for 115-volt ac input and 15-ampere fuse for 230-volt ac input and controlled by an external switch for convenient removal of power from the power supply during maintenance.

a. Prepare the power input cable as follows:

- (1) If armored cable is used, remove approximately 6 inches of armor from the end of the cable. If nonarmored cable is used, remove 6 inches of the outer insulation.
- (2) Separate the input leads and strip three-fourths inch of the insulation from the end of each lead.

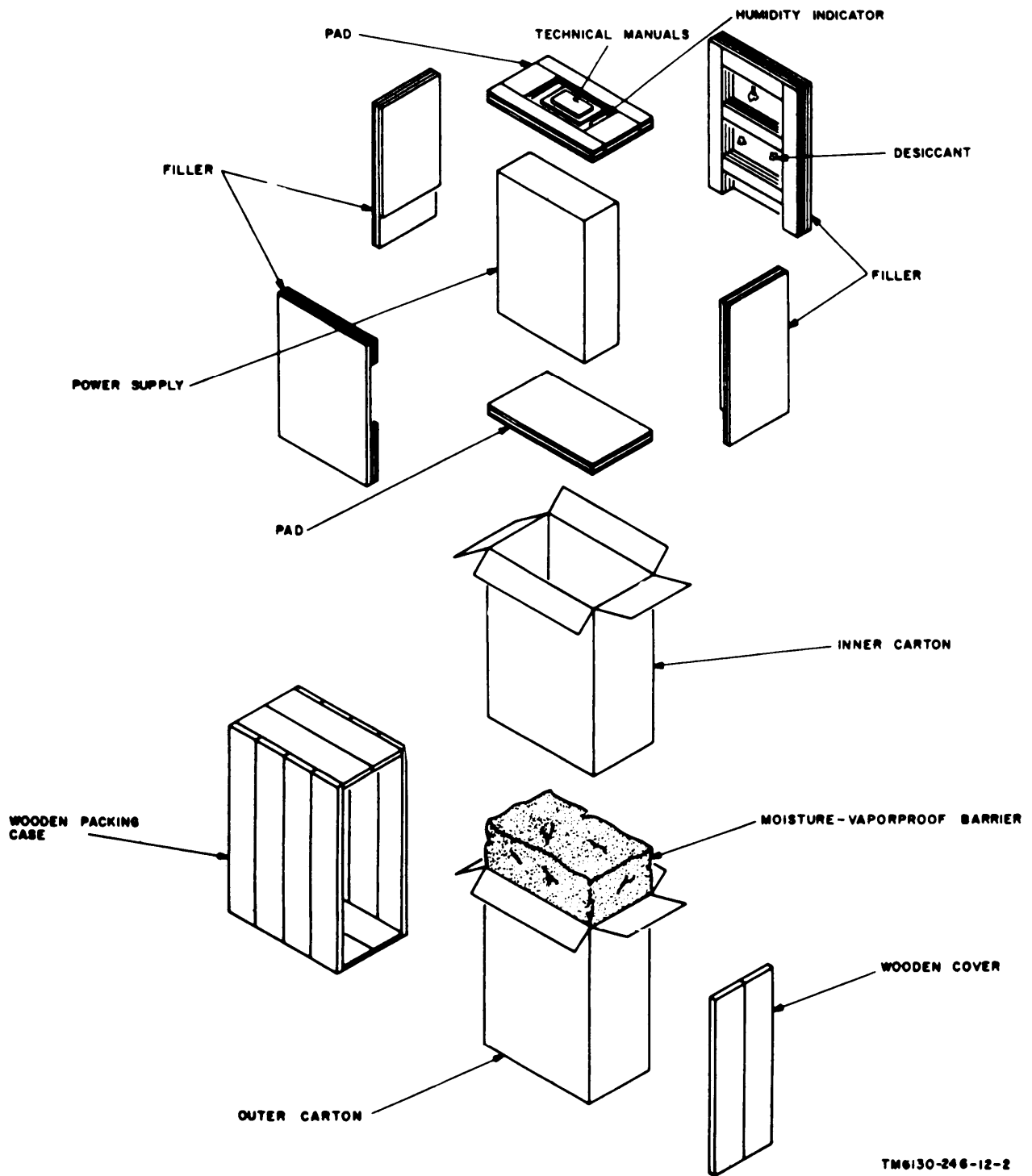

TM6130-246-12-2

Figure 2. Packaging of Power Supply PP-1104C/G.

(3) Attach a standard cable clamp to the cable.

b. Open the hinged terminal board plate (fig. 1) on the right side panel of the power supply and remove the top panel of the power supply.

c. Remove the cover and one of the knockout plugs from the outlet box (fig. 1) on the rear of the power supply. Attach the power input cable to the outlet box with the cable clamp.

d. Pass the input leads through the hole in the rear panel and attach one lead to terminal 1 (fig. 3) of the terminal board mounted on the terminal board plate (fig. 1) on the right side of the power supply. Attach the other input lead to terminal 4 (fig. 3).

e. If the power input is 115 volts, be sure that terminal 1 is strapped to terminal 3, and terminal 2 is strapped to terminal 4 on the terminal board (A, fig. 3).

f. If the power input is 230 volts, be sure that terminal 2 is strapped to terminal 3 on the terminal board (B, fig. 3).

11. Initial Adjustment of Equipment

a. Set the power supply on a level surface at the location (para 9). Use wedges to steady the power supply if necessary.

b. Set the circuit breaker switch on the front panel to OFF (fig. 4).

c. Set the increase voltage switch to 1.

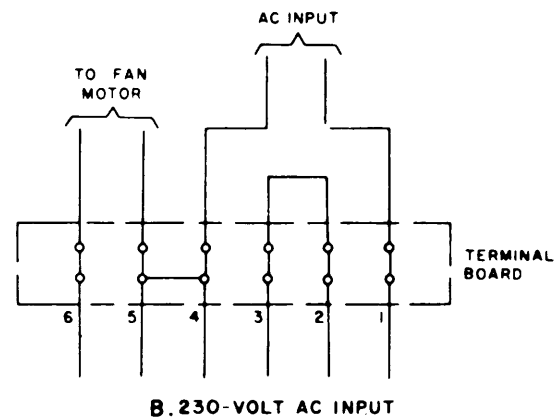
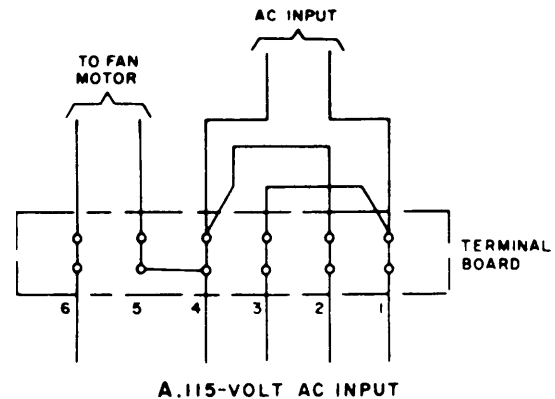

TM6130-246-12-3

Figure 3. Terminal board input connections.

Section III. OPERATION

12 Operator's Controls and Indicators (fig. 4)

The following chart lists the controls and indicators and their functions:

Control or indicator	Function
Increase voltage switch (8-position rotary)	Adjusts the dc output voltage in 8 equal steps from 11.5 volts to 17.5 volts (14-volt operation) and from 23 volts to 35 volts (28-volt operation).
Circuit breaker switch	Turns power supply on and off manually. (Two circuit breakers connected internally to circuit breaker switch

Control or indicator	Function
Indicator lamp	shut power supply off automatically when input current is excessive.)
VOLTS D.C. meter	Glows when power supply is on.
D.C. AMPERES meter	Indicator output voltage. Indicates output current.

13. Preparation for Operation

After initial adjustment (para 11), prepare the power supply for operation as follows:

a. Connect the links for the desired output as shown on the front panel placard (fig. 4).

b. Connect the equipment to be powered to the negative and positive output terminals on

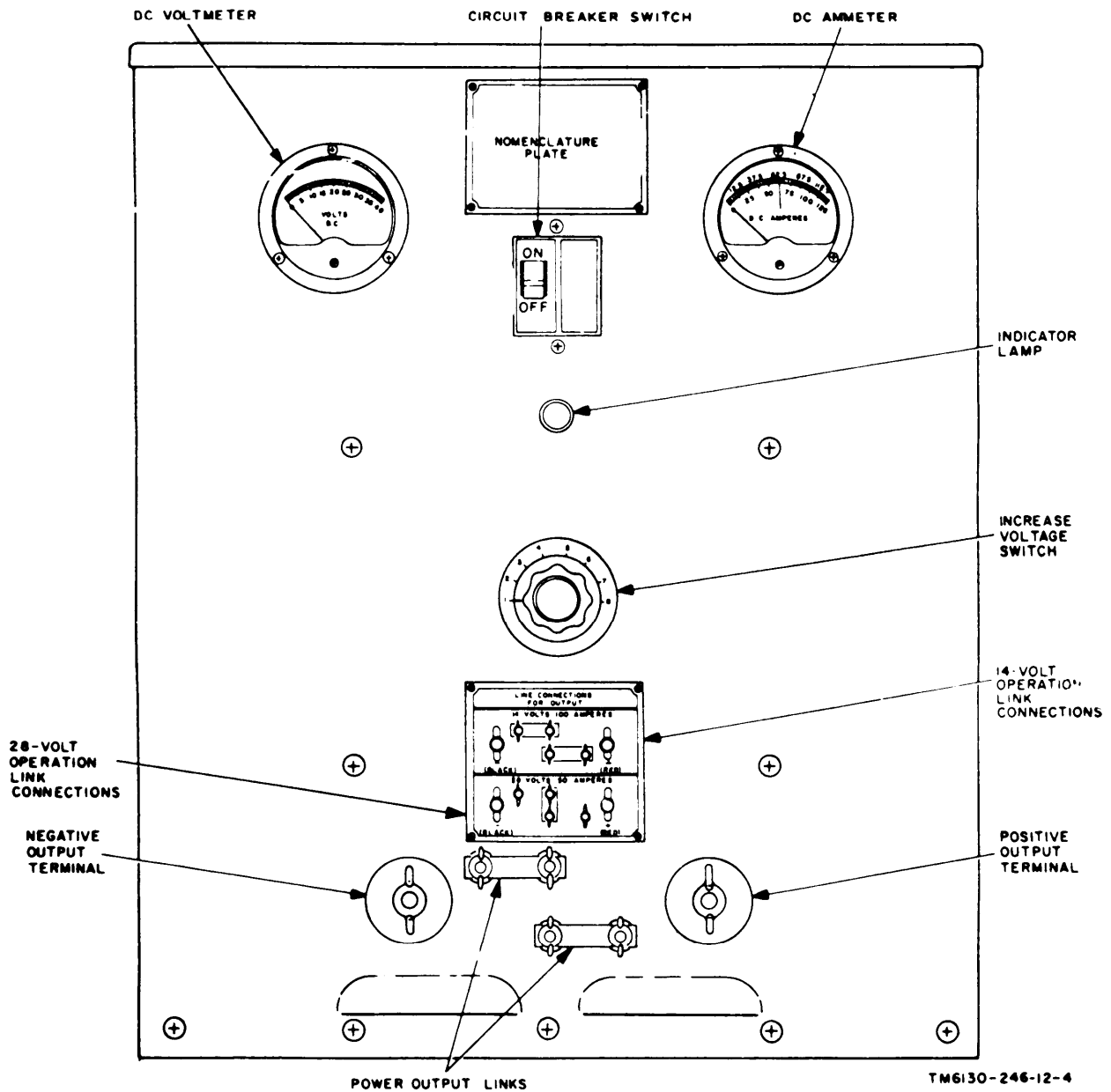

Figure 4. Power Supply PP-1104C/G, operator's control and indicators.

the front panel of the power supply. Be sure to observe correct polarity.

14. Operating Procedure

After performing the procedures in paragraph 13, proceed as follows:

a. Set the circuit breaker switch to ON. (Indicator lamp should glow.)

b. Observe the VOLTS D.C. meter indication and rotate the increase voltage switch clockwise until the desired output voltage is obtained. Turn on the equipment to be powered and readjust the output voltage by rotating the increase voltage switch. Check the output voltage at intervals during operation of the power supply. When necessary, adjust the increase voltage knob to maintain the desired output voltage.

Caution: A continuous flow of air through the power supply is necessary during operation to prevent damage due to overheating. Do not obstruct the louvers on each side of the power supply or the rear panel. If the fan should fail to operate, do not continue operation of the power supply.

15. Stopping Procedure

Stop the power supply as follows:

a. Turn off the equipment connected to the power supply output terminals.

b. Set the circuit breaker switch to OFF. (The fan should stop, the pilot lamp should extinguish, and the VOLTS D.C. and D. C. AMPERES output meters should indicate no output.)

c. Set the increase voltage switch to 1.

CHAPTER 3

MAINTENANCE INSTRUCTIONS

16. Scope of Maintenance

The maintenance duties assigned to the operator and organizational repairman of the equipment are listed below together with a reference to the paragraphs covering the specific maintenance functions. The tools and test equipment required are listed in appendix II.

- a. Daily preventive maintenance checks and services (para 19).
- b. Weekly preventive maintenance checks and services (para 20).
- c. Monthly preventive maintenance checks and services (para 21).
- d. Quarterly preventive maintenance checks and services (para 22).
- e. Cleaning (para 23).
- f. Touchup painting (para 24).
- g. Troubleshooting (para 25 and 26).
- h. Replacement of indicator lamp (para 27).

17. Preventive Maintenance

Preventive maintenance is the systematic care, servicing, and inspection of equipment to prevent the occurrence of trouble, to reduce downtime, and to assure that the equipment is serviceable.

a. *Systematic Care.* The procedures given in paragraphs 19 through 23 cover routine systematic care and cleaning essential to proper upkeep and operation of the equipment.

b. *Preventive Maintenance Check and Services.* The preventive maintenance checks and services charts (para 19-22) outline functions to be performed at specific intervals. These checks and services are to maintain Army electronic equipment in a combat serviceable condition; that is in good general (physical) condition and in good operating condition. To assist operators in maintaining combat serviceability, the chart indicates what to check, how to check, and what the normal conditions are. The References column lists the paragraphs, figures, or manuals that contain detailed repair or replacement procedures. If the defect cannot be remedied by performing the corrective actions listed, higher echelon maintenance or repair is required. Records and reports of these checks and services must be made in accordance with the requirements set forth in TM 38-760.

18. Preventive Maintenance Checks and Services Periods

Preventive maintenance checks and services of the equipment are required daily, weekly, monthly, and quarterly.

a. Paragraph 19 specifies the checks and services that must be accomplished daily (or at least once each week if the equipment is maintained in standby condition).

b. Paragraphs 20, 21, and 22 specify additional checks and services that must be performed on a weekly, monthly, and quarterly basis, respectively.

19. Daily Preventive Maintenance Checks and Services Chart

Sequence No.	Item	Procedure	References
1	Completeness	See that the equipment is complete (appx III).	
2	Exterior surfaces.	Clean the exterior surfaces including the panel and meter glasses(para 28). Check all meterglasses and indicator lenses for cracks.	
3	Connectors	Check the tightness of all connectors.	

Sequence No.	Item	Procedure	References
4	Controls and indicators	While making the operating checks (items 5 through 11), observe that the mechanical action of each knob and switch is smooth and free of external or internal binding, and that there is no excessive looseness. Aim, check the meters for sticking or bent pointers.	
5	Links	Connect links for desired output.	Figure 4.
6	L o a d	Connect load to output terminals.	Paragraph 13b.
7	Increase voltage switch	Set to 1.	
8	Circuit breaker switch	Set to ON. Note that: a. Indicator lamp glows. b. Fan starts. c. VOLTS D.C. meter and D.C. AMPERES meter indicate output voltage and current, respectively.	
9	Increase voltage switch	Rotate in steps to position 8. Note that voltage and current readings on VOLTS D.C. meter and D.C. AMPERES meter increase at each step.	
10	Circuit breaker switch	Set to OFF, Note that: a. VOLTS D.C. and D.C. AMPERES meters indicate zero. b. Fan stops. c. Indicator lamp goes off.	
11	Increase voltage switch	Set to 1.	

20. Weekly Preventive Maintenance Checks and Services Chart

Sequence No.	Item	Procedure	References
1	Cables	Inspect cords, cables, and wires for chafed, cracked, or frayed insulation. Replace connectors that are broken, arced, stripped, or worn excessively.	
2	Metal surfaces	Inspect exposed metal surfaces for rust and corrosion, Clean and touchup paint as required (para 24.)	Para 24.

21. Monthly Preventive Maintenance Checks and Services Chart

Sequence No.	Item	Procedure	References
1	Indicator lamp	Inspect seating of indicator lamp.	
2	Trandformer terminals	Inspect terminals on power transformer. All nuts must be tight. There should be no evidence of dirt or corrosion.	
8	Terminal blocks,	Inspect terminal blocks for loose connections and cracked or broken insulation.	

No. Sequence	Item	Procedurc	References
4	Resistors and capacitors	Inspect resistors and capacitors for cracks, blistering, or other detrimental defects.	
5	Gaskets and insulators	Inspect gaskets, insulators, bushings, and sleeves for cracks, chipping, and excessive wear.	
6	Fan motor	Inspect fan motor for signs of overheating.	
7	Interior	Clean interior of chassis and cabinet.	

22. Quarterly Preventive Maintenance Checks and Services Chart

Sequence No.	Item	Procedure	Reference
1	Publications	See that all publications are complete, serviceable, and current.	DA Pam 310-4.
2	Modifications . . .	Check DA Pam 3104 to determine if new applicable MWO's have been published. All URGENT MWO's must be applied immediately. All NORMAL MWO's must be scheduled.	TM 36-750 and DA Pam 910-4.
3	Spare part	Check spare part for general condition and method of storage. No overstock should be evident and all shortages must be on valid requisitions,	Appx III.

23. Cleaning

Inspect the exterior of the equipment, The exterior surfaces should be free of dust, dirt, grease, and fungus.

a. Remove dust and loose dirt with a clean soft cloth.

Warning: Cleaning compound is flammable and its fumes are toxic. Provide adequate ventilation. Do not use near a flame.

b. Remove grease, fungus, and ground-in dirt from the case; use a cloth dampened (not wet) with cleaning Compound (FSN 7930-395-9542).

c. Remove dust or dirt from plugs and jacks with 1 brush.

Caution:Do not press on the meter faces (glasses) when cleaning; the meters may become damaged.

d. Clean the front panel, meters and control knob; use a soft clean cloth. If necessary, dampen the cloth with water; mild soap may be used for more effective cleaning.

24. Touchup Painting Instructions

Remove rust and corrosion from metal surfaces by lightly sanding them with fine sandpaper. Brush two thin coats of paint on *the* bare metal to protect it from further corrosion. Refer to the applicable cleaning and refinishing practices specified in TM 9-218.

25. General Troubleshooting Information

Troubleshooting the power supply is based upon the operational check contained in the daily preventive maintenance checks and services chart (pare 19). To troubleshoot the power supply, perform all functions starting with item No. 5 in the daily preventive maintenance checks and services chart (para 19) and proceed through the items until an abnormal indication is observed; note the item number and turn to the corresponding item number in the troubleshooting chart (para 26). Perform the checks and corrective actions indicated in the troubleshooting chart. If the corrective measures indicated do not result in correction of the trouble, higher level maintenance is required.

26. Troubleshooting Chart

Item No.	Trouble symptom	Probable Cause	Checks and Corrective measures
8	<p>a. Indicator lamp does not glow.</p> <p>b. Fan does not start.</p> <p>c. VOLTS D.C. meter or D.C. AMPERES meter do not indicate properly.</p>	<p>a. Defective indicator lamp or no power input.</p> <p>b. Defective fan motor.</p> <p>c. Connections to meters faulty or defective.</p>	<p>a. Check power input. If correct, replace indicator lamp (para 27).</p> <p>b. Higher level maintenance is required.</p> <p>c. If both meters show zero reading, check for loose connection in output circuit. If only one meter shows zero, check connections to that meter. If meter connections are not faulty, higher level maintenance is required.</p>
9	<p>Voltage or current indication on VOLTS D.C. meter or D.C. AMPERES meter does not increase at each step.</p>	<p>Defective increase voltage switch.</p>	<p>Higher level maintenance is required.</p>
10	<p>VOLTS D.C. or D.C. AMPERES meters do not indicate zero, fan does not stop and pilot lamp does not go off.</p>	<p>Short circuit across circuit breaker.</p>	<p>Higher level maintenance is required.</p>

27. Replacement of Indicator Lamp

a. Turn the glass indicator jewel counterclockwise and pull it out to expose the defective lamp.

b. Press in on the indicator lamp and turn it counterclockwise to unlock it.

c. Pull the defective indicator lamp out and replace it with a new one. Push the indicator lamp in and twist it clockwise to lock it.

CHAPTER 4

SHIPMENT, LIMITED STORAGE, AND DEMOLITION TO PREVENT ENEMY USE

Section I. SHIPMENT AND LIMITED STORAGE

28. Repackaging for Shipment or Limited Storage

The exact procedure for repackaging depends on the material available and the conditions under which the equipment is to be shipped or stored. Adapt the procedure outlined below whenever circumstances permit. The information concerning the original packaging (para 7) will also be helpful.

a. Material Requirement. The following materials are required for packaging the power supply. For stock numbers of materials, refer to SB 38-100.

Material	Quantity
Corrugated single-face flexible paper	100 sq ft
Gummed paper tape	30 sq ft
Pressure-sensitive tape	26 ft
Waterproof paper	80 sq ft
Wooden packing case (Inside dimensions 26 x 21 x 16 in.)	1

b. Packaging (fig. 2). Package the items of the power supply as outlined below.

- (1) *Main unit.* Cushion the main unit on all sides with fillers and pads made up of corrugated single-face flexible paper. Secure the cushioning with gummed paper tape. Wrap the

cushioned unit with flexible corrugated single-face flexible paper and secure the wrap with gummed paper tape.

- (2) *Spare indicator lamp and technical manuals.* Wrap the indicator lamp in corrugated single-face flexible paper and secure with gummed paper tape. Wrap the technical manuals in waterproof paper and seal the package with pressure-sensitive tape. Fasten the package containing the technical manuals to the top of the power supply with pressure-sensitive tape. Fasten the spare indicator lamp package to the rear panel of the main unit with pressure-sensitive tape.

29. Packing

Pack the equipment as follows:

- a.* Use waterproof paper and pressure-sensitive tape to make a waterproof liner for the wooden packing case.
- b.* Place the consolidated package into the wooden packing case, cushion the top with corrugated single-face flexible paper, and seal the top of the waterproof liner with pressure-sensitive tape,
- c.* Nail the top to the wooden packing case.

Section II. DEMOLITION OF MATERIEL TO PREVENT ENEMY USE

30. Authority for Demolition

The demolition procedures given in paragraph 31 will be used to prevent the enemy from using or salvaging this equipment. Demolition of the equipment will be accomplished only upon the order of the commander.

31. Methods of Destruction

The tactical situation and time available will determine the method to be used when destruction of equipment is ordered. In most cases, it is preferable to demolish completely some portions of the equipment rather than partially destroy all the equipment components.

a. Smash. Use sledges, axes, hammers, crowbars, and any other heavy tools available to smash the cabinet, meters, and controls. Remove the top and side panels, and smash the internal component.

b. Cut. Use axes, handaxes, machetes and similar tools to cut the wiring of the power supply.

Warning: *Be* extremely careful with explosives and incendiary devices. Use these items only when the need is urgent.

c. Burn. Burn the technical manuals first. Burn as much of the equipment as is flammable; use gasoline, oil, flamethrowers, and similar materials. Pour gasoline on the cut cables and internal wiring and ignite it. Use a flamethrower to burn spare parts, or pour gasoline on the spares and ignite them. Use incendiary grenades to complete the destruction of the unit.

d. Dispose. Bury or scatter destroyed parts or throw them into nearby waterways. This is particularly important if a number of parts have not been completely destroyed.

APPENDIX I

REFERENCES

Following is a list of references available to the operator and organizational repairman of Power supply PP-1104C/G:

DA Pam 310-4	Index of Technical Manuals Technical Bulletins, Supply Manuals (types 4, 6, 7, 8, and 9), Supply Catalogs (type CL), Supply Bulletins, Lubrication Orders, and Modification Work Orders.	SB 38-100	Preservation, Packaging, and Packing Materials, Supplies, and Equipment Used by the Army.
		TM 9-213	Painting Instructions for Field Use.
		TM 11-6625-203-12	Operator and Organizational Maintenance: Multimeter AN/URM-105, including Multimeter ME-77/U.
		TM 38-750	Army Equipment Record Procedures.

APPENDIX II

MAINTENANCE ALLOCATION

Section I. INTRODUCTION

1. General

a. This appendix assigns maintenance functions to be performed on components, assemblies, and subassemblies by the lowest appropriate maintenance category.

b. Columns in the maintenance allocation chart are as follows:

- (1) *Part or component.* This column shows only the nomenclature or standard item name. Additional descriptive data are included only where clarification is necessary to identify the component. Components, assemblies, and subassemblies are listed in top-down order. That is, the assemblies which are part of a component are listed immediately below that component, and the subassemblies which are part of an assembly are listed immediately below that assembly. Each generation breakdown (components, assemblies, or subassemblies) is listed in disassembly order or alphabetical order.
- (2) *Maintenance function.* This column indicates the various maintenance functions allocated to the categories.
 - (a) *Service.* To clean, to preserve, and to replenish lubricants.
 - (b) *Adjust.* To regulate periodically to prevent malfunction.
 - (c) *Inspect.* To verify serviceability and to detect incipient electrical or mechanical failure by scrutiny.
 - (d) *Test.* To verify serviceability and to detect incipient electrical or mechanical failure by use of special equipment such as gages, meters, etc.
 - (e) *Replace.* To substitute serviceable Components, assemblies, or subassemblies, for unserviceable components, assemblies, or subassemblies.
 - (f) *Repair.* To restore an item to serviceable condition through correction of a specific failure or unserviceable condition. This function includes but is not limited to welding, grinding, riveting, straightening, and replacement of parts other than the trial and error replacement of running spare type items such as fuses, lamps, or electron tubes.
 - (g) *Align.* To adjust two or more components of an electrical system so their functions are properly synchronized.
 - (h) *Calibrate.* To determine, check, or rectify the graduation of an instrument, weapon, or weapons system, or components of a weapons system.
 - (i) *Overhaul.* To restore an item to completely serviceable condition as prescribed by serviceability standards developed and published by heads of technical services. This is accomplished through employment of the technique of "Inspect and Repair Only as Necessary" (IROAN). Maximum utilization of diagnostic and test equipment is combined with minimum disassembly of the item during the overhaul process.
 - (j) *Rebuild.* To restore an item to a standard as near as possible to original or new condition in appearance, performance, and life expectancy. This is accomplished through the maintenance technique of complete disassembly of the item, inspection of all parts or components, repair or replacement of worn

or unserviceable elements using original manufacturing tolerances and/or specifications and subsequent reassembly of the item.

- (3) *Operator, organization, direct support general support, and depot.* The symbol X indicates the categories responsible for performing that particular maintenance operation, but does not necessarily indicate that repair parts will be stocked at that level. Categories higher than those marked by X are authorized to perform the indicated operation.
- (4) *Tool required.* This column indicates codes assigned to each individual tool equipment, test equipment, and maintenance equipment referenced. The grouping of codes in this column of the maintenance allocation chart indicates the tool, test, and maintenance equipment required to perform the maintenance function.
- (6) *Remarks.* Entries in this column will be utilized when necessary to clarify

any of the data cited in the preceding column.

c. Columns in the allocation of tools for maintenance functions are as follows:

- (1) *Tool required for maintenance function.* This column lists tools, test, and maintenance equipment required to perform the maintenance functions.
- (2) *Operator, organization, direct support, general support, and depot.* The dagger (†) symbol in these columns indicates the categories normally allocated the facility.
- (3) *Tool code.* This column lists the tool code assigned.

2. Maintenance by Using Organizations

When this equipment is used by signal services organizations organic to theater headquarters or communication zones to provide theater communications, those maintenance functions allocated up to and including general support are authorized to the organization operating this equipment.

SECTION II MAINTENANCE ALLOCATION CHART

PART OR COMPONENT	MAINTENANCE FUNCTION	ECHOLON					TOOLS REQUIRED	REMARKS
		O/C	O	DS	GS	D		
POWER SUPPLY PP-1104C/G	service adjust	x	X				9	Preventive Maintenance Operational Set Linkage
	inspect	X	X				9	
	test	X	X				9	Operational Continuity-Input and Output Voltages Components
	test		X	X			4 5	
	repair	X			X		1,2,3,5,6,7,8,10,11	All Tests
			X		X		9	Replace Lamp
			X			7,8	Replace knobs and lens Replace Diode Assemblies, Fan and Motor, Light Assembly, Resistors, and Meters and Shunt.	
	overhaul				X		7,8	

21

SECTION III ALLOCATION OF TOOLS FOR MAINTENANCE FUNCTIONS

22

TOOLS REQUIRED FOR MAINTENANCE FUNCTIONS	ECHOLN					TOOL CODE	REMARKS
	O/C	O	DS	GS	D		
PP-1104C/G (CONTINUED)							
AMMETER ME-65/U				†	†	1	
ANALYZER ZM-3/U				†	†	2	
LOW VOLTAGE CIRCUIT TESTER TV-100 (ORD:FSN 4910-092-9136)				†	†	3	
MULTIMETER AN/URM-105		†				4	
MULTIMETER TS-352/U			†	†	†	5	
OHMMETER ZM-21A/U				†	†	6	
TOOL KIT, RADAR & RADIO REPAIRMAN TK-87/U			†	†	†	7	
WRENCH SET TE-9			†	†	†	8	
TOOL KIT RADIO REPAIRMAN TK-115/U		†				9	
TRANSFORMER, VARIABLE POWER TF-171A/U				†	†	10	
VOLTMETER, METER ME-30()/U				†	†	11	

APPENDIX III

BASIC ISSUE ITEMS LIST

Section I. INTRODUCTION

1. General

This appendix lists items supplied for initial operation and for running spares. The list includes tools, parts, and material issued as part of the major end item. The list includes all items authorized for basic operator maintenance of the equipment. End items of equipment are issued on the basis of allowances prescribed in an equipment authorization tables and other documents that are a basis for requisitioning.

2. Columns

Columns are as follows:

- a. *Federal stock number.* This column lists the 11-digit Federal stock number.
- b. *Designation by model.* Not used.
- c. *Description.* Nomenclature or the standard item name and brief identifying data for each item are listed in this column. When requi-

sitioning, enter the nomenclature and description.

d. *Unit of issue.* The unit of issue is each unless otherwise indicated and is the supply term by which the individual item is counted for procurement, storage, requisitioning, allowances, and issue purposes.

e. *Expendability.* Nonexpendable items are indicated by NX. Expendable item are not annotated.

f. *Quantity authorized.* Under "Items Comprising an Operable Equipment," the column lists the quantity of items supplied for the initial operation of the equipment. Under "Running Spare Items," the quantities listed are those issued initially with the equipment as spare parts. This quantities are authorized to be kept on hand by the operator for maintenance of the equipment.

g. *Illustration.* Not used.

SECTION II FUNCTIONAL PARTS LIST

24

FEDERAL STOCK NUMBER	DESIGNATION BY MODEL	DESCRIPTION	UNIT OF ISSUE	EXP	QTY AUTH	ILLUSTRATION	
						FIGURE NO.	ITEM NO.
6130-542-6385		POWER SUPPLY PP-1104C/G					
ORDER THRU AGC		ITEMS COMPRISING AN OPERABLE EQUIPMENT					
		POWER SUPPLY PP-1104C/G		NX			
		TECHNICAL MANUAL TM 11-6130-246 -12			2		
		RUNNING SPARE ITEMS					
6240-223-9100		LAMP GLOW: GE TYPE NE-51			1		

PP-1104C/G

3

By Order of the Secretary of the Army:

HAROLD K. JOHNSON,
General, United States Army,
Chief of Staff.

Official:

J. C. LAMBERT,
Major General, United States Army,
The Adjutant General.

Distribution:

Active Army:

USASA (2)
 CNGB (1)
 OCC-E (7)
 CofT (1)
 Cof Engrs (1)
 TSG (1)
 CofSpts (1)
 USACDCCEA (1)
 USACDCCEA,
 Ft Monmouth (1)
 USCONARC (5)
 ARADCOM (2)
 ARADCOM Rgn (2)
 USAMC (5)
 USAECOM (7)
 USAMICOM (4)
 USASMC (2)
 USAAVCOM (1)
 USASCC (4)
 OS Maj Cored (3)
 LOGCOMD (2)
 MDW (1)
 Armies (2) except
 Corps (2)
 USAC (3)
 11th Air Aslt Div (3)
 USATC AD (2)
 USATC Arm (2j)
 USATC Engr (2)
 USATC Inf (2)
 USASTC (3)
 Svc Colleges (2)
 Br Svc Sch (2)

Army Dep (2) except
 LXAD (14) SAAD (30)
 TOAD (14) FTWOAD (10)
 LEAD (5) SHAD (3)
 NAAD (5) SVAD (5)
 CHAD (3) ATAD (4)
 GENDEP (OS) (2)
 Sig Sec, GENDEP(OS) (5)
 Sig Dep (12)
 Instl (2) except Ft Monmouth (63)
 Ft Hancock (4) Ft Gordon (5)
 Ft Huachuca (10)
 Army Tml (1) except Oakland (5)
 POE (1)
 Sig Fld Maint Shops (2)
 WRAMC (1)
 USA Pic Cen (2)
 Chicago Proc Dist (1)
 AMS (1)
 USAERDAA (2)
 USAERDAW (13)
 Units org under fol TOE: (2 each UNOINDC)
 11-16
 11-57
 11-97
 11-98
 11-117
 11-166
 11-157
 11-500 AA-AE (4)
 11-557
 11-587
 11-592
 11-597

NC: State AG (3) Units same as active Army except allowance is one copy each unit.

NSAR: None.

For explanation of abbreviations used, see AR 620-50.

RECOMMENDED CHANGES TO EQUIPMENT TECHNICAL PUBLICATIONS



THEN...JOT DOWN THE DOPE ABOUT IT ON THIS FORM. CAREFULLY TEAR IT OUT, FOLD IT AND DROP IT IN THE MAIL.

SOMETHING WRONG WITH PUBLICATION

FROM: (PRINT YOUR UNIT'S COMPLETE ADDRESS)

DATE SENT

PUBLICATION NUMBER

PUBLICATION DATE

PUBLICATION TITLE

BE EXACT PIN-POINT WHERE IT IS

PAGE NO.

PARA-GRAPH

FIGURE NO.

TABLE NO.

IN THIS SPACE, TELL WHAT IS WRONG AND WHAT SHOULD BE DONE ABOUT IT.

TEAR ALONG PERFORATED LINE

PRINTED NAME, GRADE OR TITLE AND TELEPHONE NUMBER

SIGN HERE

THE METRIC SYSTEM AND EQUIVALENTS

WEIGHT MEASURE

1 Centimeter = 10 Millimeters = 0.01 Meters = 0.3937 Inches
 1 Meter = 100 Centimeters = 1000 Millimeters = 39.37 Inches
 1 Kilometer = 1000 Meters = 0.621 Miles

WEIGHTS

1 Gram = 0.001 Kilograms = 1000 Milligrams = 0.035 Ounces
 1 Kilogram = 1000 Grams = 2.2 lb.
 1 Metric Ton = 1000 Kilograms = 1 Megagram = 1.1 Short Tons

LIQUID MEASURE

1 Milliliter = 0.001 Liters = 0.0338 Fluid Ounces
 1 Liter = 1000 Milliliters = 33.82 Fluid Ounces

SQUARE MEASURE

1 Sq. Centimeter = 100 Sq. Millimeters = 0.155 Sq. Inches
 1 Sq. Meter = 10,000 Sq. Centimeters = 10.76 Sq. Feet
 1 Sq. Kilometer = 1,000,000 Sq. Meters = 0.386 Sq. Miles

CUBIC MEASURE

1 Cu. Centimeter = 1000 Cu. Millimeters = 0.06 Cu. Inches
 1 Cu. Meter = 1,000,000 Cu. Centimeters = 35.31 Cu. Feet

TEMPERATURE

$5/9(^{\circ}\text{F} - 32) = ^{\circ}\text{C}$
 212° Fahrenheit is equivalent to 100° Celsius
 90° Fahrenheit is equivalent to 32.2° Celsius
 32° Fahrenheit is equivalent to 0° Celsius
 $9/5^{\circ}\text{C} + 32 = ^{\circ}\text{F}$

APPROXIMATE CONVERSION FACTORS

TO CHANGE	TO	MULTIPLY BY
Inches	Centimeters	2.540
Feet	Meters	0.305
Yards	Meters	0.914
Miles	Kilometers	1.609
Square Inches	Square Centimeters	6.451
Square Feet	Square Meters	0.093
Square Yards	Square Meters	0.836
Square Miles	Square Kilometers	2.590
Acres	Square Hectometers	0.405
Cubic Feet	Cubic Meters	0.028
Cubic Yards	Cubic Meters	0.765
Fluid Ounces	Milliliters	29.573
its	Liters	0.473
arts	Liters	0.946
allons	Liters	3.785
Ounces	Grams	28.349
Pounds	Kilograms	0.454
Short Tons	Metric Tons	0.907
Pound-Feet	Newton-Meters	1.356
Pounds per Square Inch	Kilopascals	6.895
Miles per Gallon	Kilometers per Liter	0.425
Miles per Hour	Kilometers per Hour	1.609

TO CHANGE	TO	MULTIPLY BY
Centimeters	Inches	0.394
Meters	Feet	3.280
Meters	Yards	1.094
Kilometers	Miles	0.621
Square Centimeters	Square Inches	0.155
Square Meters	Square Feet	10.764
Square Meters	Square Yards	1.196
Square Kilometers	Square Miles	0.386
Square Hectometers	Acres	2.471
Cubic Meters	Cubic Feet	35.315
Cubic Meters	Cubic Yards	1.308
Milliliters	Fluid Ounces	0.034
Liters	Pints	2.113
Liters	Quarts	1.057
ers	Gallons	0.264
ms	Ounces	0.035
ograms	Pounds	2.205
Metric Tons	Short Tons	1.102
Newton-Meters	Pounds-Feet	0.738
Kilopascals	Pounds per Square Inch	0.145
ometers per Liter	Miles per Gallon	2.354
ometers per Hour	Miles per Hour	0.621



PIN: 020683-006